

INVESTIGATION OF GLIDER SAFETY BELT BEHAVIOR UNDER ACCIDENT CONDITIONS

by Detlef Pusch and Martin Sperber (West Germany)

Presented at the XXI OSTIV Congress, Wiener-Neustadt, Austria (1989)

1. OBJECTIVE

Glider accidents in which the passengers were severely or fatally injured while the gliders themselves suffered only slight damage, or none at all, led to the question whether safety belt systems in gliders offer optimum protection from the point of view of present-day safety research.

In order to answer this question, the Federal Minister of Transport commissioned TUV Rheinland with an investigation of glider safety belt behaviour under accident condi-

tions. Wherever applicable, possibilities for optimizing safety belt systems were to be derived from the results of the investigation.

2. ACCIDENT ANALYSIS

The prerequisite for such an investigation is knowledge about the type of accidents and the forces occurring during them. The first step was, therefore, to carry out an accident analysis. It covered 911 glider accidents registered in the

Federal Republic of Germany from 1983 to 1986. The classification of the accidents according to the extent of the injuries suffered by the passengers is apparent from the following diagram.

Analysis of 911 Glider Accidents (1983 through 1986)



In line with the objective of this study, only accidents with fatal and severe injuries and with ground contact as primary contact were then analyzed in greater detail. 129 accidents are in this category.

3. SELECTION OF REPRESENTATIVE ACCIDENT TYPES

Evaluation of the accident records of these 129 accidents and discussion of the knowledge obtained from them with representatives of the Federal Aviation Authority, glider clubs and glider manufacturers resulted in the 4 representative accident types listed below.

Accident type 1:

This type represents accidents after an unsuccessful winch launch in the initial start phase (e.g. cable break or premature release) and accidents in the landing phase, in which the landing is terminated too high.

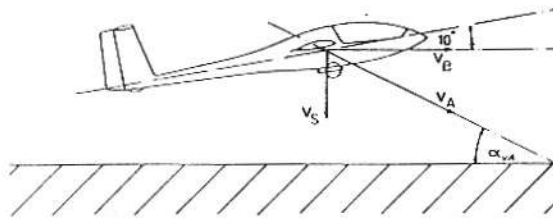

Longitudinal slop : 10° nose up
 Side tilt : 0°
 Angle of sideslip : 0°
 Surface : soil

Accident type 2:

This accident type represents accidents in the landing phase which are caused by too late flaring, or none at all.

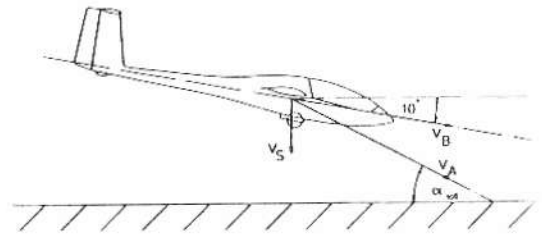

Longitudinal slop : 17.8° nose down
 Side tilt : 0°
 Angle of sideslip : 0°
 Surface : soil

Accident type 3:

This type simulates off-field landing with rotation around the vertical axis on account of a wing coming into contact with the ground or moderate stalling accidents from a slight height.

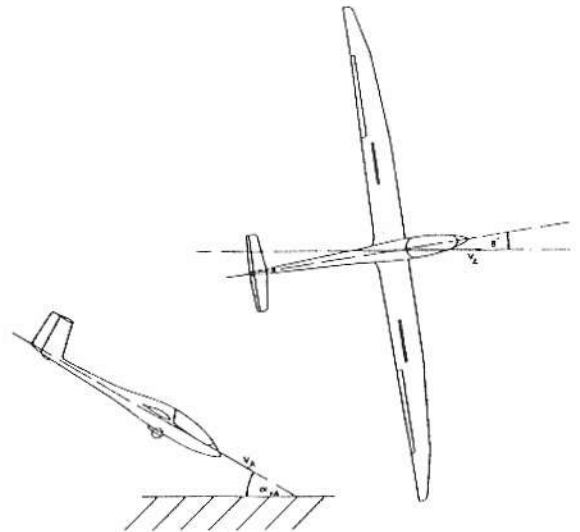

Longitudinal slop : 30° nose down
 Side tilt : 0°
 Angle of sideslip : 8°
 Surface : soil

Accident type 4:

This accident type represents serious accidents as a result of stalling and spinning from a considerable height.

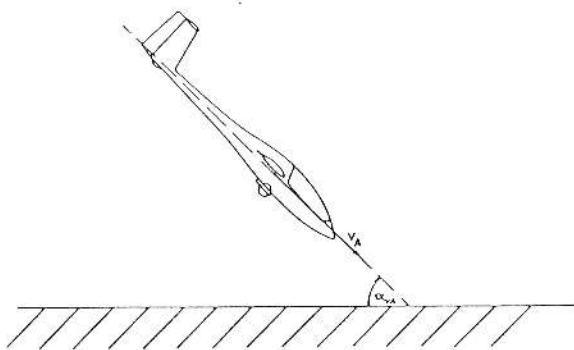
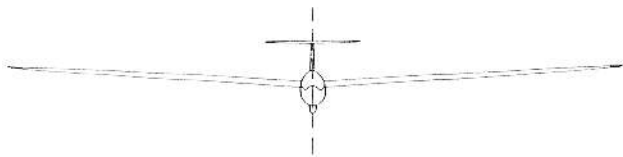

Longitudinal slop : 45° nose down
Side tilt : 0°
Angle of sideslip : 0°
Surface : soil

These 4 representative accident types cover approximately 52% of the 129 evaluated accidents.

4. FIELD TESTS

At the beginning of the study, no reliable information was available on the loads experienced by the aircraft structure and the passengers in real glider accidents.

It was not possible to draw conclusions on either the occurring mass forces or their time of action from the accident record, i.e. from the position and degree of damage of the aircraft structure, the extent and type of injuries suffered by the passengers, deformation of the ground in the impact area, etc. However, such data were an absolute prerequisite for simulation of accidents on the crash lane. Therefore, the magnitude, direction and time of action of forces occurring during accidents were first established experimentally in field tests.

In order to achieve maximum compliance with real accident situations, the following boundary conditions were assured during the field tests:

- use of fuselage noses of representative glider samples,
- realization of actual mass ratios by attaching compensating masses,
- realization of real impact angles,
- step-by-step increase in velocity to reach typical impact velocities,
- approximation of actual impact conditions (plowed land),
- use of a dummy,
- installation of the sensors in the center of gravity of the test object in the direct proximity of the dummy. Types 1 and 4 of the four defined accident types were selected for the simulation of accidents in field tests. In this context, the selection criteria were the combination of:
 - type of injury,
 - severity of injury and
 - accident frequency.

The test setup used for the field tests is illustrated in the following picture.

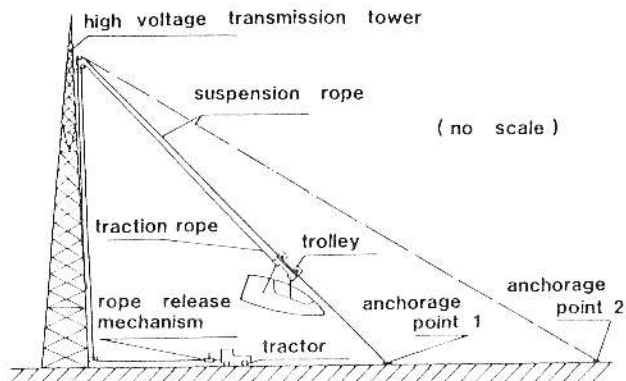

The test site was a harvested beet field on which a decommissioned pylon was located. Using this test setup, the magnitude, direction and time of action of the deceleration values occurring in the center of gravity of the test object during the accident were determined for the two selected accident types.

Evaluation by means of measurements covered only the primary collision phase, which is the most important part of the entire impact process. The maximum transformation of energy takes place in this phase, i.e. the test object loses approximately 90% of its impact energy here.

The results of the field tests are given in the following survey:

serial No. of test	drop height (m)	velocity (m/s)	mean deceleration		duration of the primary impact	
			x-dir. (g)	z-dir. (g)	x-dir. (ms)	z-dir. (ms)
Accident type 4						
1	1	4,2	3,4	0,3	124	124
2	2,5	6,9	4,3	0,7	161	161
3	36	21,9	9,2	0,1	229	229
Accident type 1						
4	0,5	2,8	1	2,4	100	100
6	7,5	11,8	4,8	11,9	60	60

With reference to the test results for accident type 1, it is important to remember that the test object was not equipped with landing gear. Consequently, the deceleration values apply for accidents with raised landing gear.

On the basis of the deceleration values obtained in the field tests and taking consideration of the influence of the missing wings and tail of the fuselage of the test object, a default deceleration impulse was defined for simulation of the two selected accident types on the crash stand. These default impulses are apparent from the next two diagrams.

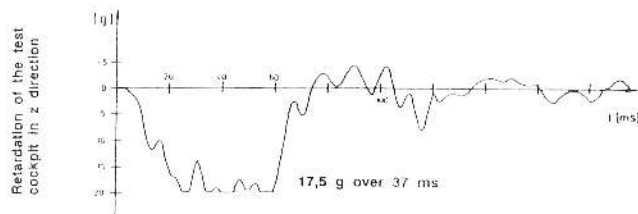

Retardation impulse (crash test) for accident type 1

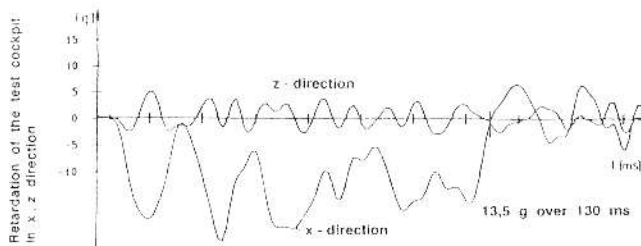

Retardation impulse (crash test) for accident type 4

The deceleration impulses measured during the field test were simulated by trapezoidal impulses with regard to height and time of action. This is an internationally agreed method which has been used in safety research in the motor vehicle sector for years.

5. CARRIAGE IMPACT TESTS

5.1 Test Setup

The test setup for simulation of the two accident types is illustrated in the following pictures.

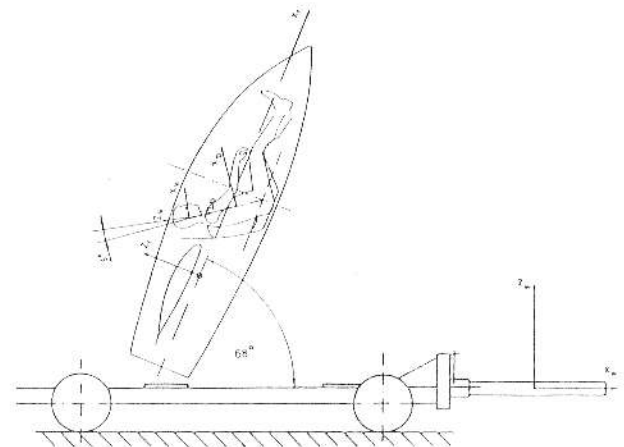

Set-Up for crash tests: Accident type 1

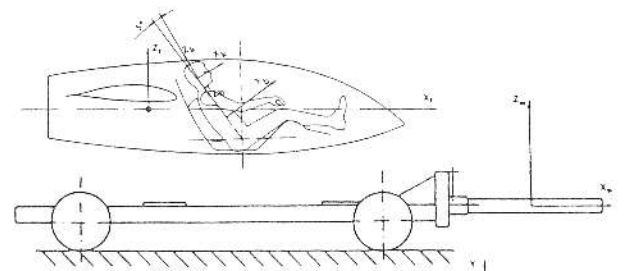

Set-up for crash tests: Accident type 4

The load values determined in the field tests were also achieved in the simulation with suitable positioning of the test object on the impact carriage and the default impulse.

5.2 Measuring equipment

The following specification shows the measuring equipment used for the crash tests.

1. Dummy

- Head 3 acceleration pickups (x, y, z)
- Chest 3 acceleration pickups (x, y, z)
- Pelvis 3 acceleration pickups (x, y, z)
- Thighs 2 load transducers (left, right)

2. Belt system
 - 2 load transducers in the upper torso strap (left, right)
 - 1 load transducer in the jockstrap
 - 2 load transducers in the lap belts (left, right)
3. Test structure (glider)
 - 2 acceleration pickups in the cockpit mass center (x, z direction)
4. Test sled
 - 1 acceleration pickup in the test sled (x direction-horizontal)
5. 2 high-speed cameras.

5.3 Performance of the Test

The carriage impact tests were carried out with the following belt systems:

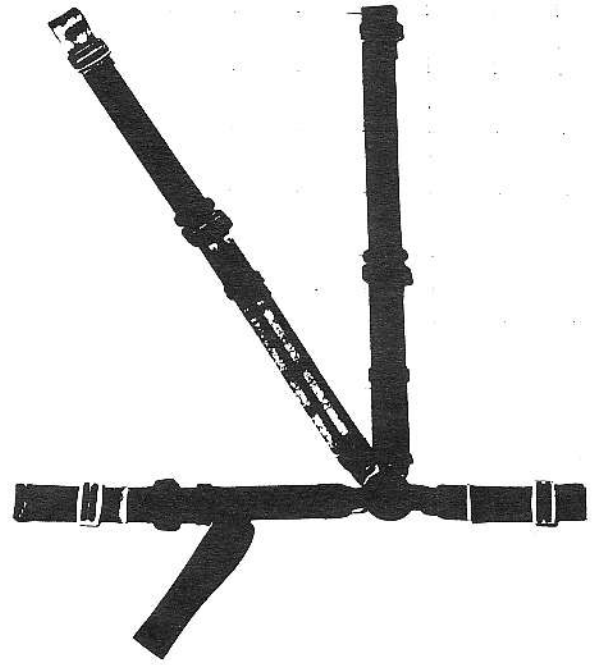

Autoflug asymmetrical belt

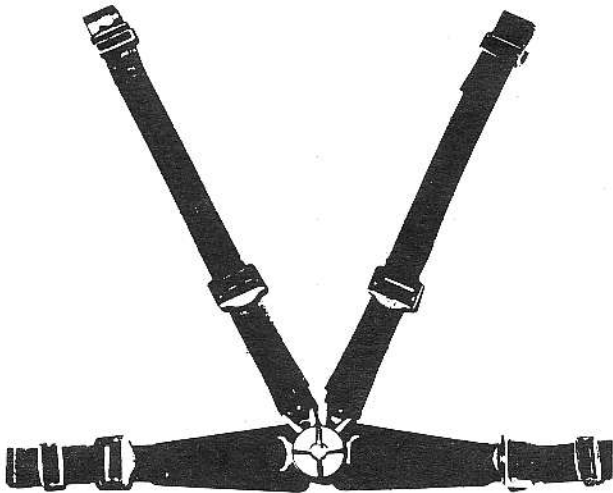

Gardringer 4-point belt

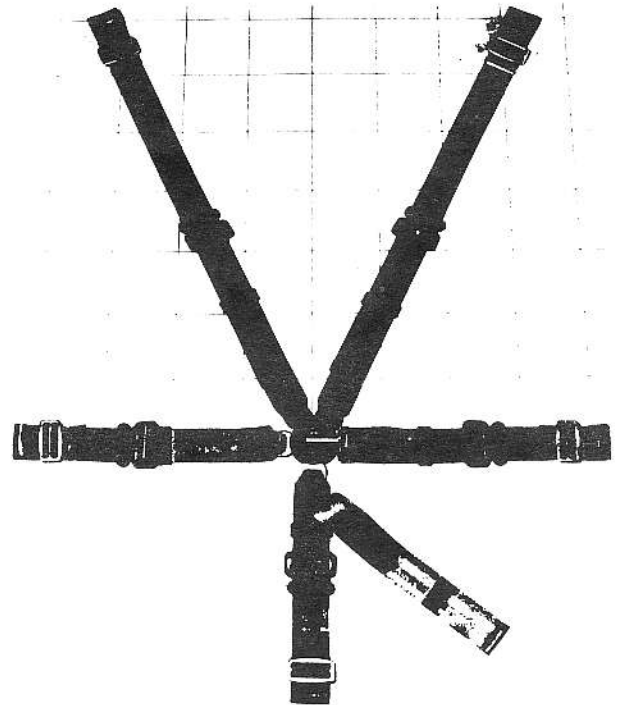

Autoflug 5-point belt

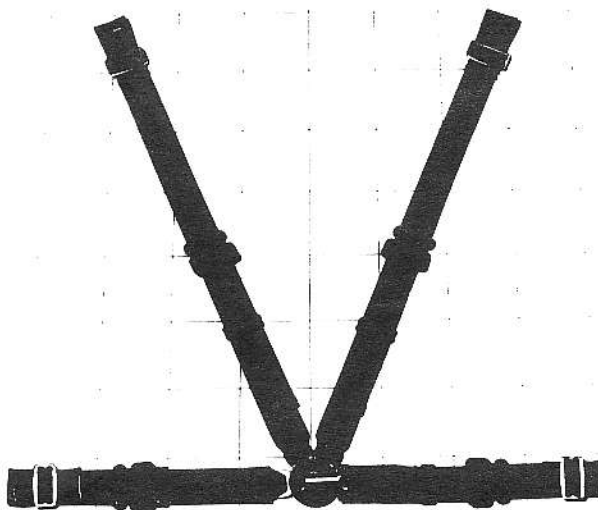

Autoflug 4-point belt

For accident type 1, these belt systems were subjected to the deceleration impulses with 2 different backrest inclination positions in each case, and for accident type 4 with 3 different backrest inclination positions in each case.

5.4 Behaviour of Conventional Safety Belt Systems in Crash Tests

For accident type 1:

1. Very high loads in the dummy in z direction: head 43,8 g; chest 47,5 g; pelvis 43,5 g.
2. The restraining effect is achieved by the seatpan alone.
3. All forces occurring in z direction hit the human body undamped.

For accident type 4:

1. The restraining effect is achieved by the belt system and the seatpan.
2. The forces in z direction measured in the dummy are to be considered critical.
3. Microslip and slip in all belt fittings. Microslip means minimum slip between webbing and adjustment hardware from friction not being infinite.
4. Due to the jockstrap the forward displacement of the pelvis was found to be moderate with 5-point belts.
5. Extreme forward displacement of the pelvis and, hence, distinct submarining occurred with all 4-point belts.
6. The problem of injuries to internal organs caused by submarining is to be considered an issue calling for attention.

Evaluation of the high-speed films pointed to unfavorable lap belt geometry as a result of the positioning of the anchor points.

Measurements performed in some modern gliders and questions directed at manufacturers indicated a relatively flat angle range (20-40 degrees) for the lap belt geometry. However, from motor vehicle research it is known and has been verified that a more right angled lap belt geometry reduced the submarining effect. Further tests were, therefore, performed with varied belt anchor points for accident type 4.

5.5 Modified Lap Belt Anchorage Points

In the case of accident type 4, if the lap belt anchorage points are selected well, i.e. in the range of 70 degrees to 90 degrees to the H point, it is possible to reduce the forward displacement of the pelvis by up to 35% with considerable reduction of dangerous submarining! **Note:** The H point which indicates the position in the cockpit of a seated occupant, is the trace of the theoretical axis of rotation between the legs and the torso of the human body. It is determined by means of a dummy.

5.6 Carriage Impact Tests with Varied Belt Systems

Three belts which have not been licensed to date, were examined in a further series of tests. The systems are apparent from the following pictures:

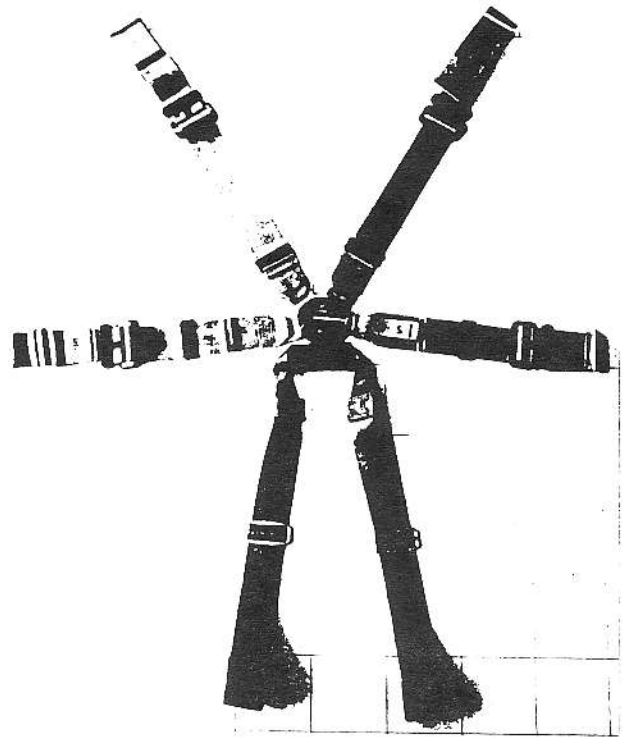

Autotflug 6-point belt

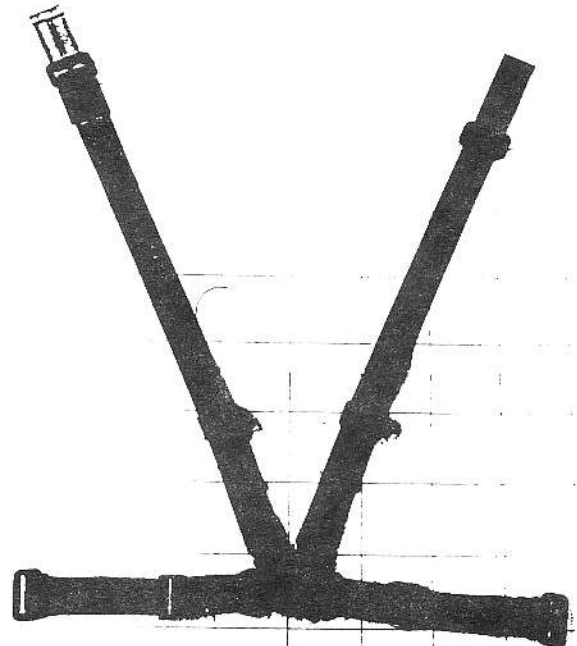

Schroth 4-point-ASM belt

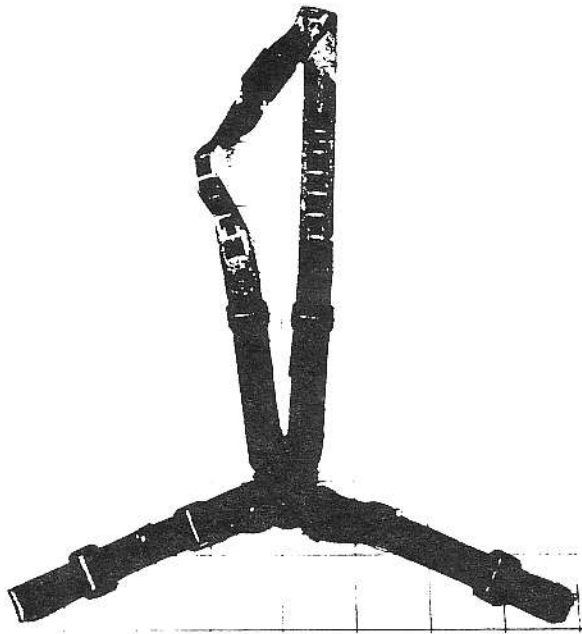

Schroth 4-point-Y-ASM belt

The 6-point belt is a normal 4-point belt with 2 additional belts around the thighs.

The 4-point ASM manufactured by Schroth is a 4-point belt system with an energy converter in the upper part of one shoulder belt. ASM means anti-submarining. The energy converter (a tear-open seam) is designed for a specific tensile load. On reaching this load, the seam tears open, releasing an additional belt section which lengthens the shoulder belt. This means that the body is turned around its longitudinal axis by a few angular degrees at an early stage of forward movement. As a result, the pelvis presses against the lap belt earlier and tightens it. This time, difference between tightening of the lap belt and the shoulder belts is generally sufficient to fix the lap belt around the pelvic bones in such a way that the shoulder belts cannot pull it up towards the abdomen.

In the 4-point Y-ASM belt, the shoulder belts are joined together in the upper section and are anchored at one point. The purpose of this Y-shaped join is to prevent the belt sliding to the side in the loaded and unloaded condition.

5.6.1 Results

6-point belt:

The forward displacement of the pelvis is further reduced by some 15% as compared with the 4-point belt, with the drawback being that the jockstraps are difficult to fasten and to tighten and are less convenient to wear.

4-point ASM:

The forward displacement of the pelvis is reduced by up to 14% as compared with the conventional 4-point belt and there were no indications that Y-shaped diagonal belts tended to slip down the shoulders.

6. CONCLUSION AND PROPOSALS FOR IMPROVEMENTS

As there was no failure of belt material but some microslip and slip in the belt fittings, I would propose to sew the fittings on the belt strap and design it to be screwable.

With some microslip and slip in the adjustment hardware, I would propose some design adjustment hardware with minor adjustment forces, such that microslip and slip is prevented.

As the overlapping of the parachute belt system and restraint system favors sliding of the lap belt into the soft tissues, I would propose, if possible, to do without smooth metal parts between the two belt systems.

Though 5-point and 6-point belt systems reduce the forward displacement of the pelvis, these systems are detrimental as the jockstrap pinches the soft tissues, it is very troublesome to put the belts on and to tighten them, they do not wear well, and they are an additional obstacle to overcome when getting out of the cockpit.

A normal 4-point belt, provided with an energy converter, is as effective in reducing forward displacement of the pelvis as a 6-point belt is.

Optimization of the system will help produce even more favorable results. In all types of accidents, the seatpan was found to act as a restraint system with no energy absorption in z direction. I would propose to design the seatpat to be energy absorbing.

Forward displacement and hence, submarining can be controlled by the geometry of the belt.

What is of prime importance is an optimum mounting area of effective lap belt anchorages. **Important note:** The restraining effect of a 4-point belt is achieved only if the lap belt is tightened. Prior to landing, the lap belt shall be as closely fitting as possible. The upper torso straps shall be much less tight.

7. PROSPECTS

- Development of an energy absorbing seatpan and proper backrest.
- Influence of the angle of the seatpan on the forward displacement of the pelvis and the relevant lap belt anchorage point.
- Development and design of adjustment hardware with minor adjustment forces to prevent microslip and slip.
- Further optimization of the 4-point belt with energy converter. (Optimization of the safety joint; material of greater elasticity should be used for the diagonal belts.)
- Optimization of the diagonal belt anchorage points by means of crash test.