

PROBLEMS AND IMPROVEMENTS OF CANOPY JETTISONING SYSTEMS

by W.Röger and P.Stabenau, Fachhochschule, Aachen, Germany

Presented at the XXII OSTIV Congress, Uvalde, Texas, USA (1991)

Summary

The paper "Evaluation of Canopy Jettisoning System for Sailplanes", read at the OSTIV Congress in 1989, pointed out the magnitudes of the aerodynamic forces and moments acting on the canopy. This paper now presents details of the motion and flight path of the canopy after its release in an emergency. The tests were performed with an LS 4 fuselage mounted on the roof of a car. During these tests the influence of the speed, angle of attack, side slip angle and the automatic raising of the front and the side were investigated. It becomes apparent that none of the existing mechanical systems installed in a today's glider

guarantee a problem-free jettisoning of the canopy. The canopy does not fly away, it blocks the exit and there is a high risk of injury to the pilot by the moving canopy. The main reason for this is a nose-down pitching and the nose-inwards yawing moment acting on the canopy. The occupant is unable to control the motion of the canopy during jettisoning. To overcome this problem the nose down moment can be transformed into a nose-up moment by a simple rear hinge between the top of the canopy and the fuselage. The hinge may take the form of a simple clasp. This clasp ensures that after the release the canopy rotates around this hinge with a nose-up moment, separates from the fuselage and passes high above the rudder. There is no

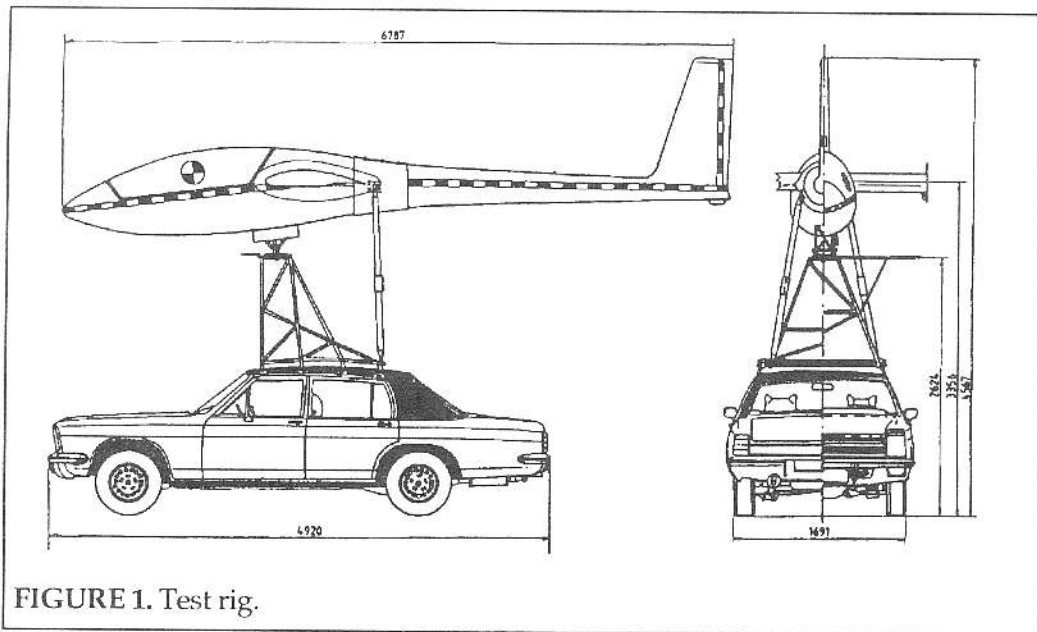

FIGURE 1. Test rig.

risk of injury to the occupant. Manual jettisoning can be performed without any trouble using this hinge.

1. Introduction

Over the past twenty years there have been a number of glider accidents in which the occupants were killed because they were either unable to jettison the canopy or they had difficulties in jettisoning the canopy in time. For this reason the German Federal Ministry of Transport commissioned the Fachhochschule Aachen to evaluate existing canopy jettisoning systems and to provide a data base for a future revision of the Joint Airworthiness Requirements 22. Part of the first paper on this program⁽¹⁾ was read at the XXI OSTIV Congress in 1989 in Wiener Neustadt⁽²⁾. It presented details of an accident analysis, the time required to jettison the canopy and the magnitudes and directions of the aerodynamic forces and moments acting on the canopy. This paper now presents the results of the further program in which the motion, dynamic behaviour and flight path of the canopy during jettisoning were investigated. This was done using a special test rig⁽³⁾. The influence of the airspeed, angle of attack, side slip angle and the raising of the front part of the canopy as well as a lateral raising were examined. Due to the low magnitude of the aerodynamic force and the nose down pitching moment on the canopy⁽⁴⁾ no satisfying results with existing jettisoning systems could be achieved. Certain improvements were therefore discussed and tested. In addition, tests for investigating the handling of the canopy were carried out to show the problems involved in manual jettisoning.

2. Test rig

The tests were performed with an LS4 fuselage mounted on the roof of a car (Figure 1) at the NATO Air Base in

Geilenkirchen (Germany). The attitude of the fuselage could be varied to adjust the angle of attack (± 30 degrees) and the side slip angle (± 30 degrees). In order to compare the results with the values measured in the wind tunnel, where most of the tests were carried out at the maximum airstream of 130 km/h (70 kt), the maximum speed of the car was 140 km/h (76 kt). The speed of the test rig was measured by a pitot-static probe.

In these tests different mechanisms were installed to raise the canopy at the front or side of the LS 4 cockpit. The release was triggered by the front-seat passenger. The motion and the flight path of the canopy were recorded by video-cameras.

at the front or side of the LS 4 cockpit. The release was triggered by the front-seat passenger. The motion and the flight path of the canopy were recorded by video-cameras.

3. Results with existing constructions

Without any raising the canopy rests on the fuselage and a motion cannot be registered independent of the magnitude of the angle of attack. This confirms with the wind tunnel results, showing that up to a speed of 160 km/h (86 kt) the aerodynamic force is less than the weight of the canopy. Above this speed the aerodynamic force is able to lift off the canopy.

It is possible to jettison the canopy with a side slip angle greater than 15 degrees. Separation from the fuselage takes place very slowly and the canopy hits the panel, occupant, wing and finally the rudder. This is unacceptable since it delays and endangers the exit.

3.1 Front raising

Nowadays there are some systems which attempt to increase the aerodynamic forces by raising the front part of the canopy. This should accelerate the cockpit motion after release and the canopy should move upwards without any danger of hitting the pilot. Figure 2 shows the motion of the canopy in this case.

The mechanism at first lifts the front of the canopy (Figure 2, I) and then due to the nose down pitching moment the rear of the canopy comes up (II). In this nose down attitude the airstream at first presses the front and then the rear of the canopy down onto the fuselage (III). It remains in this position, slightly towards the rear of the cockpit, and blocks the exit (IV). This behaviour was observed at all speeds up to 140 km/h and with all tested magnitudes of the front raising up to $H=200$ mm (8 in).

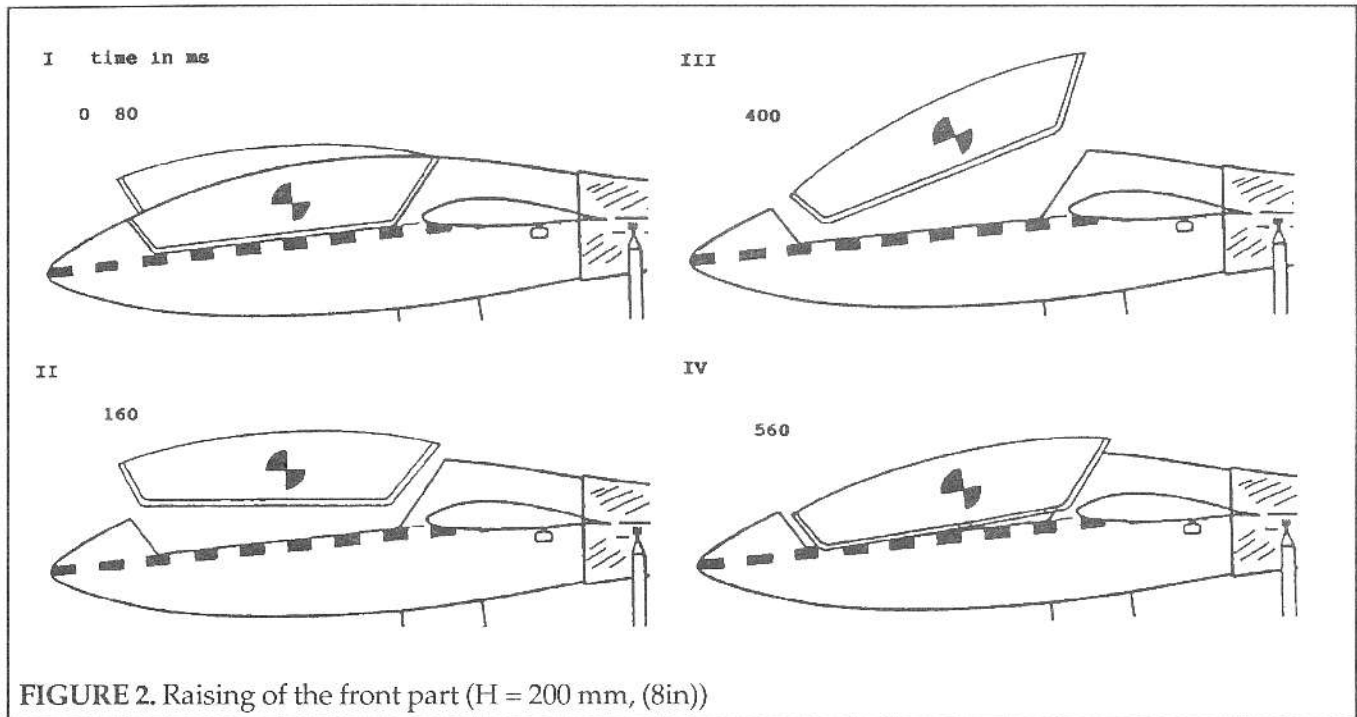

FIGURE 2. Raising of the front part (H = 200 mm, (8in))

In case of a sidewind with the canopy in the raised position, it separates from the fuselage but the front part turns into the cockpit and may hit the pilot (Figure 3).

This shows that a raising of the front part does not automatically initiate a jettisoning of the canopy and it does not represent a satisfactory solution for jettisoning the canopy.

3.2 Lateral raising

In certain sailplanes the procedure for jettisoning the canopy is to release the canopy on the left side, to raise this slightly, and then to release the right side and push the canopy away. This was tested using a mechanism which lifts the canopy to an adjustable opening angle, and releases the right hinge after this angle is reached. Figure 4 shows the results of such a test. The canopy at first rotates around the right hinge, the right hinge was then released at the pre-set opening angle and the canopy moves free from the fuselage. It finally lifts off with a nose down movement whereby the front part simultaneously turns back into the cockpit due to a nose inwards yawing moment ⁽⁵⁾. It then passes the cockpit on the left

side without gaining height, flies over the left wing and finally strikes the vertical tail on the right side, having crossed over the rear fuselage on its way back.

It goes without saying that this method cannot be seen as a satisfactory solution for jettisoning the canopy.

In a further test the right hinge was not released (Figure 5). The canopy rotates around the right hinge to an opening angle of 180 degrees. The plastic screws of the hinges then broke and the canopy flew back below the right wing and hit the tail. This may be the only way to jettison the canopy with no risk to the occupant.

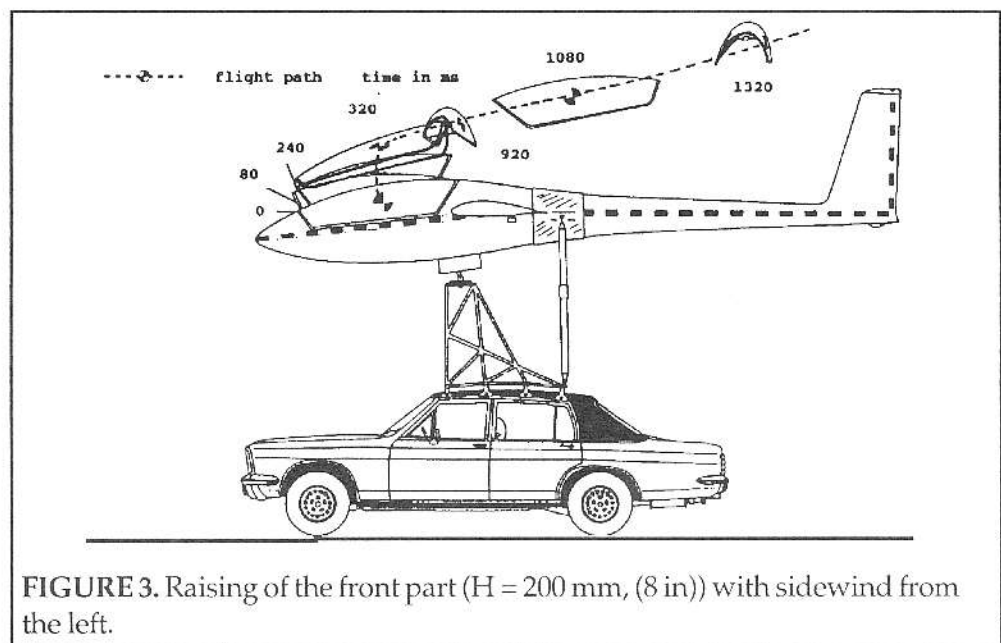

FIGURE 3. Raising of the front part (H = 200 mm, (8 in)) with sidewind from the left.

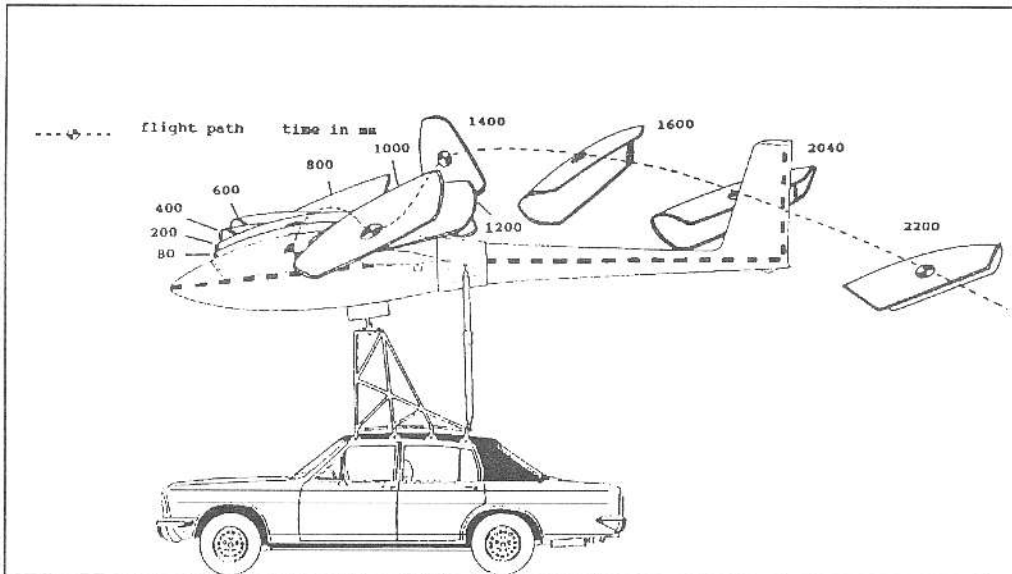

FIGURE 4. Lateral raising.

3.3 Manual jettisoning

Further tests were carried out to determine whether the pilot himself could operate and jettison the canopy with no risk of being hit. These tests were performed with an occupant in the cockpit of the test rig. Two handles were installed on the left and right side of the canopy frame whose position could be changed. There were no problems with the forces for raising the canopy, but owing to the nose-down pitching moment the front part of the canopy always rests on the fuselage. To overcome this effect the handles were positioned in front of the center of gravity. This should initiate a nose up moment during manual raising. It is found that the pilot is able to raise the canopy at the front but the canopy's nose is immediately pushed down by the airstream, and within 40 ms the front part strikes the fuselage. It is impossible for the occupant to control the canopy. This is why a planned rear manual jettisoning was cancelled.

After a long discussion it was decided to jettison the canopy to the right manually. The pilot wore a leather jacket and crash helmet and the strut of the canopy was padded. The pilot pushed the canopy as quickly as possible to

the right, but due to the nose down pitching and the nose-inwards yawing moment the front part turned downwards into the cockpit. The canopy slid backwards, hit the pilot with the strut and used the pilot's arms as a chute. Fortunately the occupant's arms were in a protective position due to the jettisoning operation. Otherwise the strut would have injured his face.

It must be pointed out that the pilot is unable to control the canopy movement during manual jettisoning and that there is a high risk of injuring to the pilot by the canopy.

4. Possible improvements

There is only one way to improve this situation: to transform the nose down into a nose up pitching moment. Three different solutions have been suggested.

The first is an additional weight at the rear of the canopy. In order to produce a nose up moment a weight of more than 80 N (18 lb) would be necessary. It goes without saying that this alternative was quickly dismissed.

The second solution is a change of the position and size of the canopy. In a theoretical study⁽⁶⁾ calculations were carried out for 46 different shapes by means of the pressure distribution measured in wind tunnel tests. The results

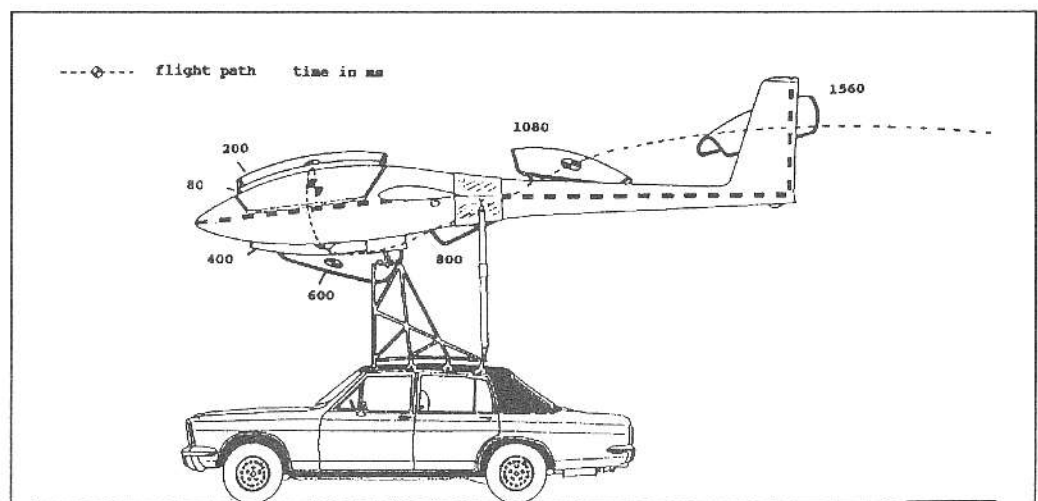

FIGURE 5. Lateral raising without release of the right hinge.

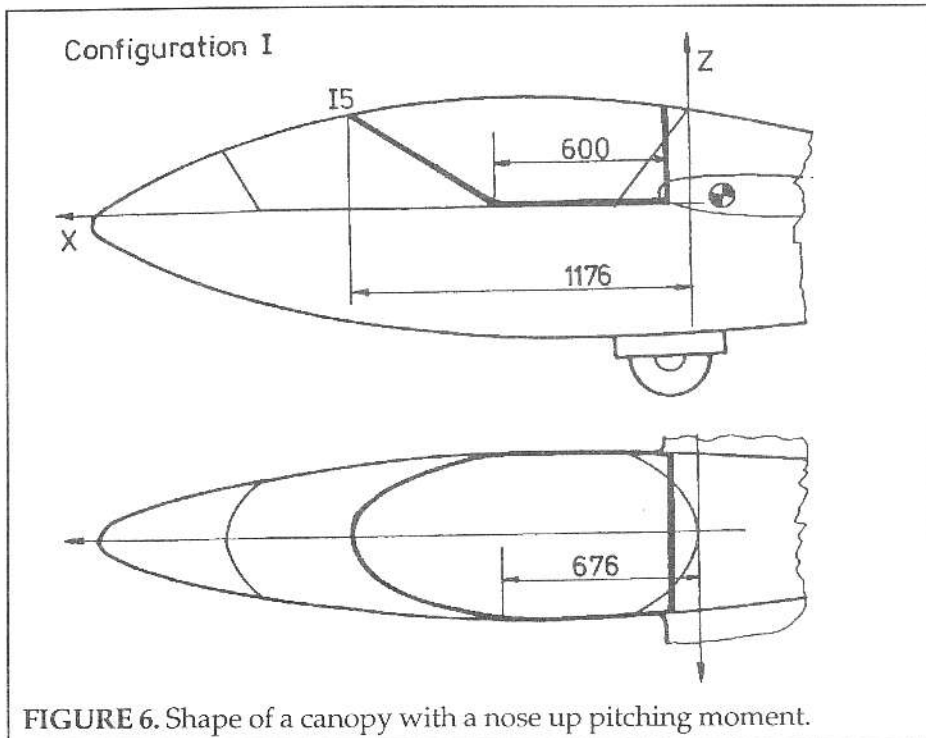

FIGURE 6. Shape of a canopy with a nose up pitching moment.

showed that there is only one shape which produces a slight nose up moment over the total range of angle of attack and airspeed. Figure 6 shows this theoretical canopy. The canopy must shift backwards to the largest fuselage diameter, the back should be upright to shift the center of gravity backwards and the front and aft opening should be as small as possible (600 mm (23.6 in)) is the minimum value according to the OSTIV standards). The front displays an angle of between 35 and 40 degrees. This shape would only appear possible for the rear canopy of a double seater but impractical for a single seater.

The third solution is a rear hinge between the top of the frame and the canopy. This makes it possible for the canopy to rotate with a nose up moment after the release. Such a hinge can be realized as a clasp (Figure 7). This solution was tested.

5. Jettisoning with a hinge at the top

These tests were carried out at speeds of between 75 km/h (40 kt) and 130 km/h (70 kt) with and without raising.

With no raising of the front part the canopy rests on the fu-

selage and jettisoning does not take place.

5.1 Front raising

With the front raised the canopy comes away with no help from the pilot. The speed should be above 100 km/h (54 kt) with a raising greater than 60 mm (2.4 in) and angle of attack higher than -5 degrees. The results of the wind tunnel test must be kept in mind: the normal force is lower than the weight up to a raising of around 60 mm⁽²⁾.

Figure 8 shows the canopy motion and the flight path at a speed of 130 km/h and raising of 200 mm. Immediately after release the canopy rotates upwards around the hinge and at an angle of around 30 degrees the canopy separates from

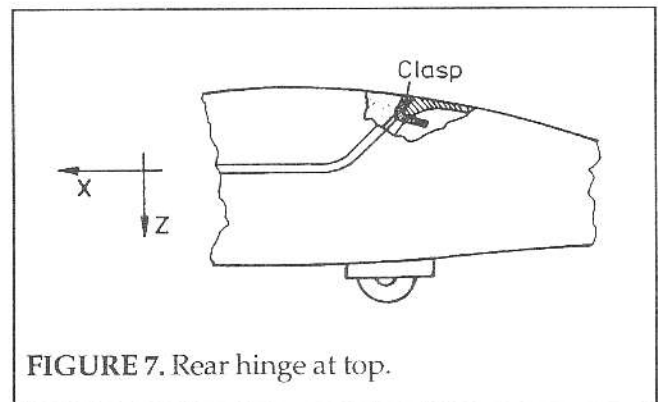

FIGURE 7. Rear hinge at top.

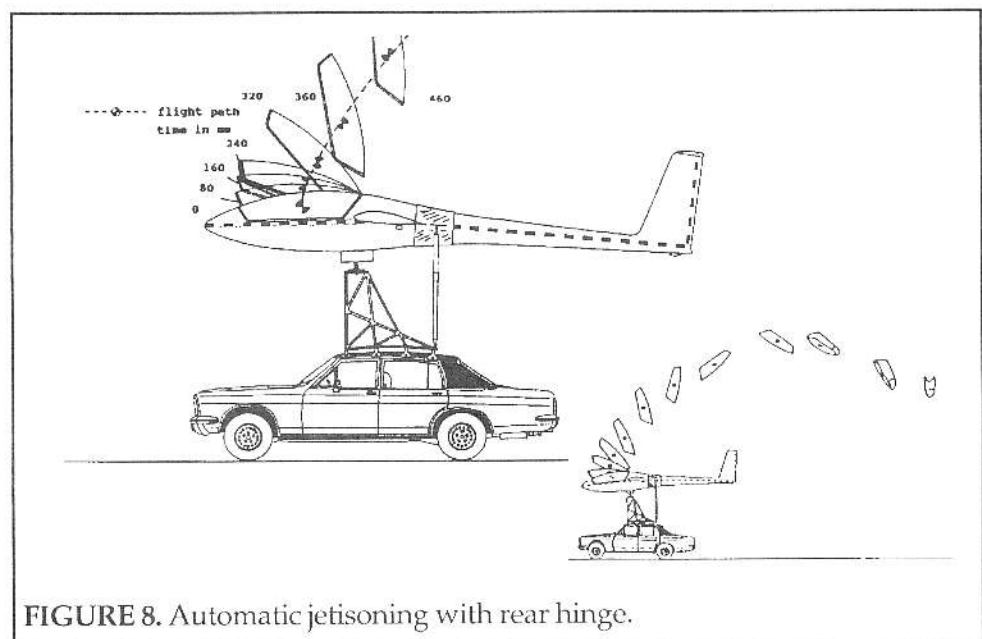

FIGURE 8. Automatic jettisoning with rear hinge.

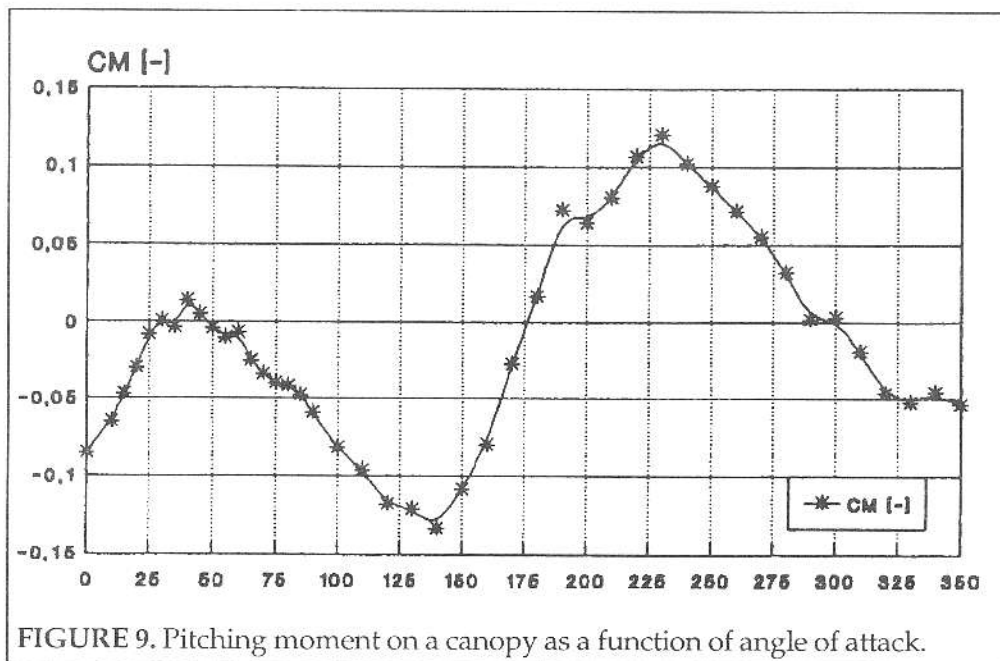

FIGURE 9. Pitching moment on a canopy as a function of angle of attack.

With a side slip angle the canopy also rotates around the hinge with the difference that the flight path is now displaced to the lee-side.

This hinge produces an ideal canopy flight path with a nose-up moment.

The nose up pitching moment during the free flight of the canopy was proven in a further wind tunnel test (7). The aerodynamic forces and the moments as well as the aerodynamic coefficients were measured as a function of the angle of attack. Figure 9 shows the results of the pitching moment. There is only a small range between 25 and 50 degrees angle of attack with a nose-up moment.

the fuselage. The normal force now pulls the canopy upwards with a slight nose up pitching moment. The canopy passes the rudder at a height of approximately 4 m (13 ft). The time required for the canopy to separate from the cockpit is approximately 0.4 s. There is no risk of injury to the pilot.

This is the angle at which the hinge must be released to produce a high flight path with a nose up rotation during jettisoning.

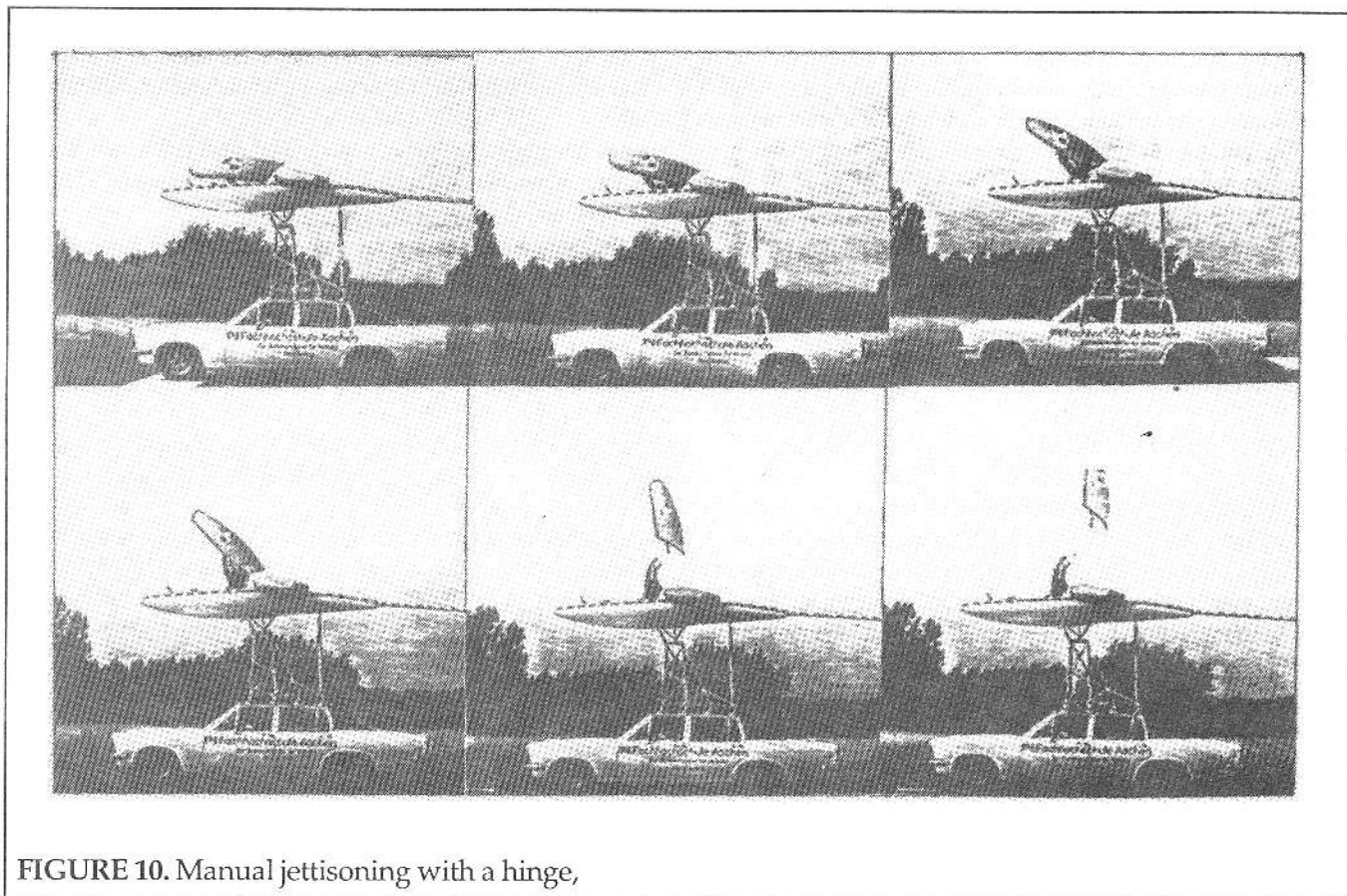

FIGURE 10. Manual jettisoning with a hinge,

5.2 Manual Jettisoning

The tests with the clasp were very encouraging and it was decided to test some manual jettisoning with such a clasp. Two handles were installed on the left and right frame in a good handling position. Four persons took part in these tests at different speeds. During all tests no difficulties were experienced with jettisoning. Figure 10 shows one of these tests.

The pilot pushes the canopy upwards and as soon as the canopy reaches an angle of approximately 25 degrees the aerodynamic forces tear the canopy out of the occupant's hands, the canopy rotates around the hinge, separates from the fuselage and flies high above the rudder. After 0.4 s the cockpit is free for an emergency exit.

A further test was carried out to determine whether any difficulties can be expected with a negative value of the angle of attack and to check the force the pilot must provide. The angle was adjusted to -10 degrees. In this position the normal force is much lower than the weight. It would appear that there is no problem in jettisoning the canopy. The pilot is able to raise the canopy with little effort. After raising it slightly the airstream lifts the canopy automatically. In this case the occupant needs two handles on the canopy frame to initiate raising.

6. Conclusion

It is clear that none of the existing mechanisms in today's gliders guarantee a problem-free jettisoning of the canopy and that there is a high risk of injury to the pilot by the moving canopy. The main reason for this is the nose down pitching and nose-inwards yawing moment on the canopy. This is due to the position of the center of pressure which is behind the center of gravity. This nose down moment can be transformed into a nose up pitching moment by a rear hinge between the top of the canopy and the fuselage. This hinge can take the form of a simple clasp. In such cases the hinge must be released at an angle of

approximately 40 degrees between the canopy and the cockpit. This simple improvement means that after the release the canopy rotates with a nose up pitching moment, separates quickly from the cockpit and passes high above the rudder. There is no risk of injury to the pilot.

An automatic jettisoning assumes a raising of the front part. At low speeds and a low angle of attack the raising does not initiate the separation of the canopy. For this reason there should be two handles on the right and left frame of the canopy which the pilot can use to assist jettisoning. These handles should also be used to release the canopy. This is why there should be two handles in any canopy jettisoning system.

7. References

- (1) Röger, W., Conradi, M., Renner, A. Untersuchung über Haubennotabwurfsysteme bei Luftfahrtgerät, Forschungsbericht FE-Nr. 500075/87 FH Aachen, FB 6, 1990.
- (2) Röger, W., Conradi, M. Evaluation of Canopy Jettisoning Systems for Sailplanes, OSTIV-Congress 1989, Wiener Neustadt.
- (3) Stabenau, P. Experimentelle Haubenabwurfversuche am Beispiel des Segelflugzeuges LS 4, Diplomarbeit FH Aachen, FB 6, März 1991.
- (4) Braun, M., Golembiewski, R. Experimentelle Ermittlung der Auftriebs und Widerstandskräfte an einer Segelflugzeughaube, Diplomarbeit FH Aachen, FB 6, August 1989.
- (5) Kubitzka, A. Experimentelle Ermittlung der aerodynamischen Kräfte an einer seitlich aufgeklappten Segelflugzeughaube, Diplomarbeit FH Aachen, FB 6, März 1990.
- (6) Dülmer, L. Berechnung der Luftkräfte an Segelflugzeughauben verschiedener Abmessungen, Diplomarbeit FH Aachen, FB 6, März 1990.
- (7) Lofi, A. Luftkräfte an der Cockpithaube eines Segelflugzeuges, Diplomarbeit FH Aachen, FB 6, August 1990.