

Some remarks about Akaflieg designs and Idaflieg-history

Hans-Ludwig Meyer

halu.meyer@t-online.de

*Head (retd.) DLR Flight Research Department Braunschweig
Braunschweig, Germany*

Abstract

In the early twenties of last century, students from several universities of technology throughout Germany organized themselves in so-called “Akademische Fliegergruppen” (academic flying groups) or, shortened, Akaflieg’s. Being flight enthusiasts, their main emphasis was (and still is) laid on improving soaring flight with respect to performance and safety of sailplanes. Consequently, during the past hundred years a variety of prototypes evolved from Akaflieg design activities – some can be regarded as milestones of sailplane development, others revealed major shortcomings of initially promising concepts. The first part of the paper gives a short overview on selected Akaflieg projects from 1922 until now. Furthermore, the “Interessengemeinschaft deutscher Akademischer Fliegergruppen” (Idaflieg, Interest group of German Academic Flying Groups), which is the, also self-organized, umbrella association of the Akaflieg’s, is presented. Within the frame of Idaflieg, design and construction workshops as well as flight test campaigns are conducted. The second part of the paper is dedicated to a short description of these student’s activities.

Introduction

In the early twenties of last century, students that were organized as “Akademische Fliegergruppen” (Academic Flying Groups) of the universities of technology in Aachen, Berlin, Darmstadt and Hanover took part in the very first Rhön-competitions, where they flew the gliders that they had designed and built. During these meetings, they would sit together and discuss technical and aerodynamic aspects of their designs. But it also turned out that the student groups had similar financial and organizational problems, which led to the idea of forming and joining the “Interessengemeinschaft deutscher Akademischer Fliegergruppen” (Interest group of German Academic Flying Groups), abbreviated “Idaflieg”. This accumulation of common interests has also provided the grounds for the exchange of experiences and a joint representation to the public. The first reference of the Idaflieg is a short notice about its founding during the “3rd Rhön Competition” by the Akaflieg groups in August 1922.

More Akaflieg groups that were working on technical-scientific projects joined the Idaflieg in the following years. From the very beginning, meetings were organized to help each other in order to improve glider performances, flying techniques and flight safety. This cooperation between the Akaflieds remains to this day by mutual support, exchange of knowledge and skills as well as test flying and assessing each others designs.

The Idaflieg history can be split into three periods, like the German history of the last hundred years: a first period from 1922 to 1933 (“Weimarer Republik”), a second one from 1933 to

1945 (“Nationalsozialismus”) and finally the period from 1951 until today.

During the first German democracy after World War I, some remarkable sailplane designs from Akaflieg-groups supported the great progress in soaring. An example is the series of the Akaflieg Darmstadt types, the so called “Darmstädter Schule”. Flying together competitively as well as making observations and having discussions about the observed led to greatly improved understanding of atmospheric characteristics and how to gain altitude (or, respectively, potential energy) in areas of lift.

In 1933, the groups received a letter informing them that they were no longer allowed to exist as independent clubs and had to join the recently established National Socialist soaring association. A former member of the Akaflieg Darmstadt, Otto Fuchs, arranged it so that the Akaflieg groups were supervised and supported by the DVL (Deutsche Versuchsanstalt für Luftfahrt, German Aeronautical Research Institute, one of the predecessors of today’s German Aerospace Center DLR), the greatest and oldest German aviation research establishment. Outside of the national-socialist influence, the Akaflieg Darmstadt and others created many remarkable sailplane designs under the umbrella of the DVL.

In 1951 soaring was permitted again in West Germany, and Akaflieg groups were reestablished in the west. Soon, the student groups realized several innovative projects that are still having great impact on the development in soaring. New materials and a better understanding of aerodynamics and flight mechanics were integrated and tested in small and big steps. Ultimately,

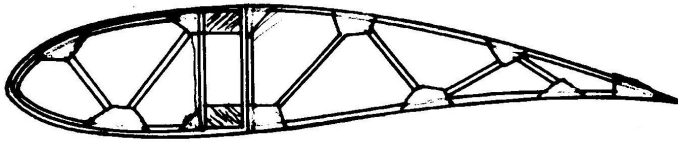

Fig. 1: Wing cross section of the “Vampyr”.

this has led to the incredible distances and altitudes that have been flown with sailplanes all over the world.

Beside of the technical-scientific projects of the Akaflieg groups, the flight performance (Vergleichsfliegen) and handling-quality measurements (“Zachern”, named in honor of Hans Zacher) that are performed during the annual Idaflieg summer meetings (Idaflieg Sommertreffen) and discussed during the Idaflieg winter meetings (Idaflieg Wintertreffen), have contributed substantially to the high standards of modern high-performance sailplanes. During the summer meetings, students are routinely trained on the procedures and investigations of judging and criticizing sailplane cockpits, sailplane handling and responses to standard control inputs and maneuvers. Many aspects of present certification standards and test procedures are based on the results of such Idaflieg events.

Design activities of Idaflieg-groups

Many different airplanes, sailplanes and powered gliders have been designed by the twelve to fifteen groups that have belonged to the Idaflieg during the last hundred years in very different political environments and ever changing societies in Germany. But the main focus was always laid on the development of sailplane technology and some of the projects conducted are milestones concerning performance and safety improvement. Such advances continue to be possible because of the application of new materials and configurations that otherwise would be considered too risky outside the relatively uncomplicated environments of the Akafliegs and their comparatively independence from commercial pressure. As a consequence, several Akaflieg projects have also identified concepts and technologies considered risky, exotic and unconventional.

Besides designing entire sailplanes using new materials or the latest aerodynamic knowledge, the Idaflieg-groups with their various projects are contributing to the advancement of flight safety, the introduction of novel rescue systems, and the extended use of modern electronic instrumentation and data displays. These projects are often discussed and tested during the regular Idaflieg meetings. Currently, ten Akaflieg groups that are members of the Idaflieg, work on scientific and technical projects and participate in the Idaflieg activities.

Examples of remarkable historic airplane projects

The first glider with flights that exceeded flight times of three hours was the H1 “Vampyr” in 1922, a design by the Akaflieg Hannover. The “Vampyr” was setting the way for the evolution

of gliders and became the “grandfather” for many following successful designs. For example, the overall drag was reduced by using a high-aspect ratio wing as Prof. Ludwig Prandtl had suggested. Furthermore, several structural solutions were groundbreaking. The wing profile was sufficiently thick, Fig. 1, so that the wing could be built as a self-supporting structure that did not require strong external bracing. The main structural elements of the “Vampyr” wing were an internal spar for carrying the bending and shear loads and a D-tube leading-edge design for reacting the wing torsion loads. The pilot was sitting in a low-drag fuselage, Fig. 2. The basic principles, that are even present in most modern high-performance sailplanes, made the “Vampyr” an important milestone in sailplane evolution.

The next sailplane projects by Idaflieg-groups were primarily initiated by an improved understanding of meteorological phenomena and lift theories, making possible longer flights with higher speeds over greater distances to given destinations – the beginning of systematic cross-country flying. However, the students attained improvements in increments, each new design meant a step forward.

In this respect the family of the Akaflieg Darmstadt designs of the twenties and thirties, the so called “Darmstädter Schule”, were further groundbreaking. As an example, Fig.3 shows the Darmstadt D 9 “Konsul” from 1923 which already exhibits a cantilever high-wing configuration with the struts removed for the sake of reduced parasitic drag, while the induced drag was kept low by introducing an aspect ratio (AR) of 16.5.

Of course, increasing the aspect ratio of a sailplane wing delivers an enhanced maximum glide ratio. Consequently, this development was continued with the Akaflieg Darmstadt D 19 “Darmstadt II” from 1928 (Fig. 4, showing an AR of 18.2) and finally culminated in a very demanding project that was started by the Akaflieg Darmstadt in 1933, the Darmstadt D 30 “Cirrus”, Fig. 5. Students managed to be unrestricted by the amount of manpower available and had no financial limits to aim for a maximum of performance. Bending and torsion forces were



Fig. 2: “Vampyr” replica at the Segelflug-Museum Wasserkuppe.

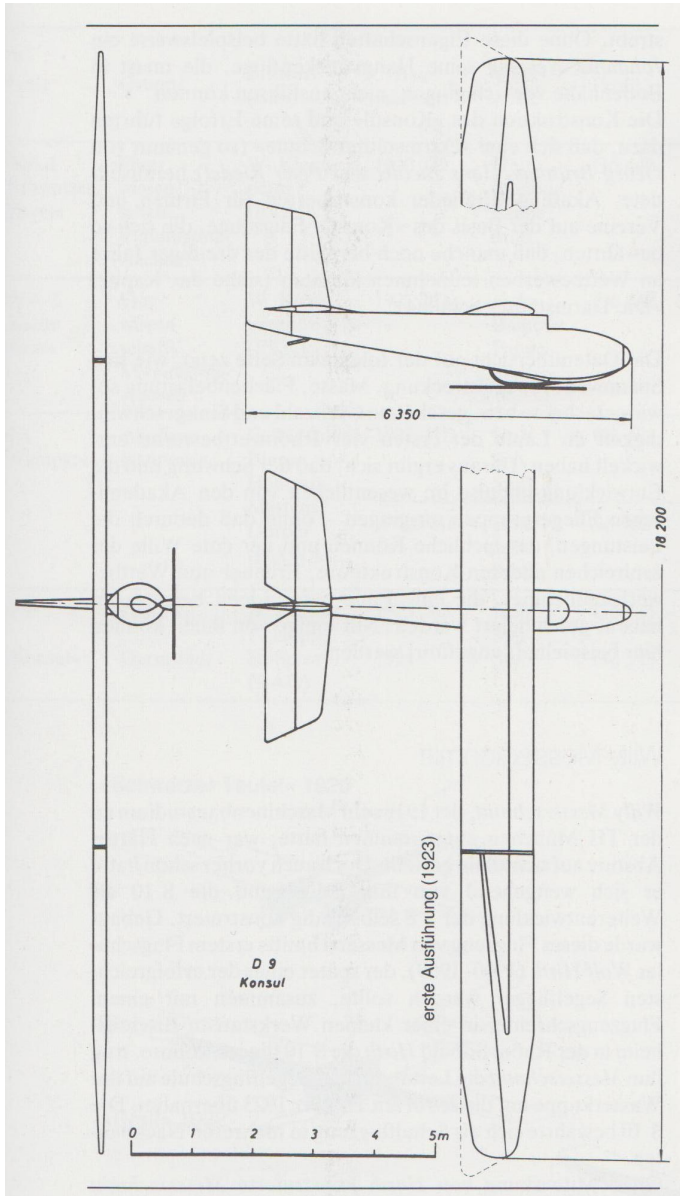

Fig. 3: Akaflieg Darmstadt D 9 “Konsul”, 1923.

carried by a box-type spar of aluminum alloy. The leading edge and aft section of the wing were constructed using preformed plywood. Ultimately, an AR of 34 was realized with these new techniques. First flight of the D 30 was in 1938. The dihedral of the outer wings was adjustable on the ground between -4.4° and $+8.5^\circ$ in order to investigate the impact on lateral flight stability characteristics (Fig. 6). Furthermore, the D 30 was used to study the impact of differential aileron deflections on the roll-yaw coupling. Performance measurements showed a best glide ratio of 37 at 77 km/h and a minimum sink rate of 0,55 m/s at 72 km/h with 0° dihedral.

Another example of the innovative contributions of Idaflieg-groups is the family of sailplanes that originated from the

Akaflieg München (Munich). The distinctive framework of welded steel tubes as fuselage structures as well as wings and tail-surfaces that are made out of wood is typical for the “Münchener Schule”, another successful series of sailplane designs.

The 2-seater Mü 10 “Milan”, Fig. 7, is the grandfather of many following Akaflieg München projects. Its performance was remarkable but the flying qualities were challenging. In particular the control of the roll axis required special control techniques due to very high adverse yaw. The “Milan” survived the war and was stored in a museum until 1951. After gliding was allowed again it was overhauled by the Akaflieg and flown until 1962. Nowadays the “Milan” is part of the airplane exhibition at the Deutsches Museum in Munich.

The next design was the Mü 13 “Atalante”, Fig. 8, a high-performance single-seat sailplane that is based on the design principles of the “Milan”. With the Mü 13 the students were successful at several championships and were able to perform

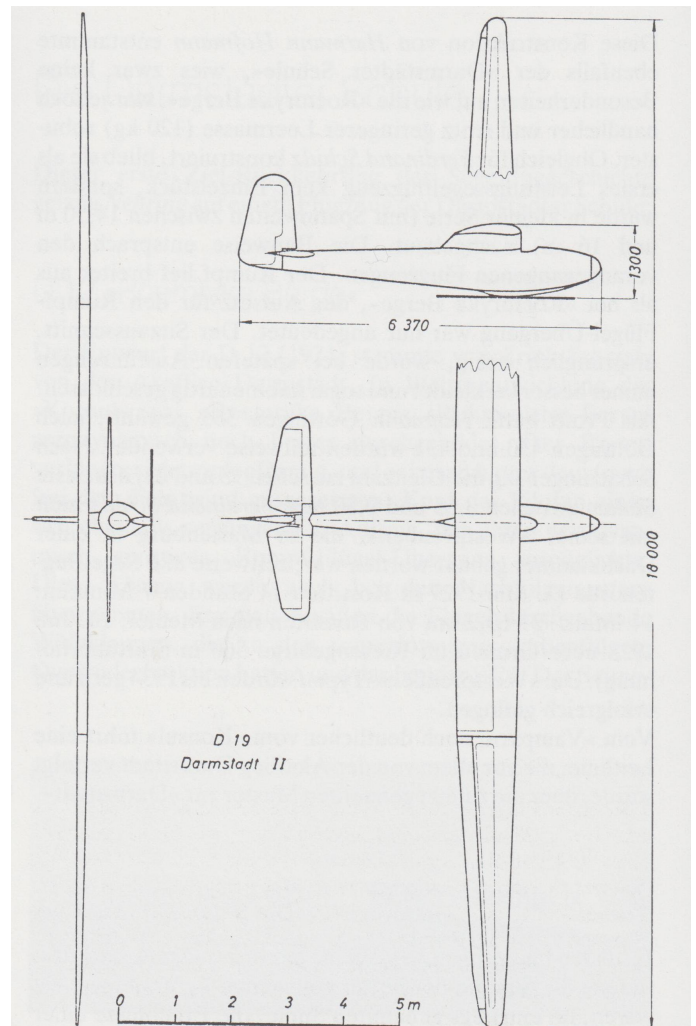

Fig. 4: Akaflieg Darmstadt D 19 “Darmstadt II”, 1928.

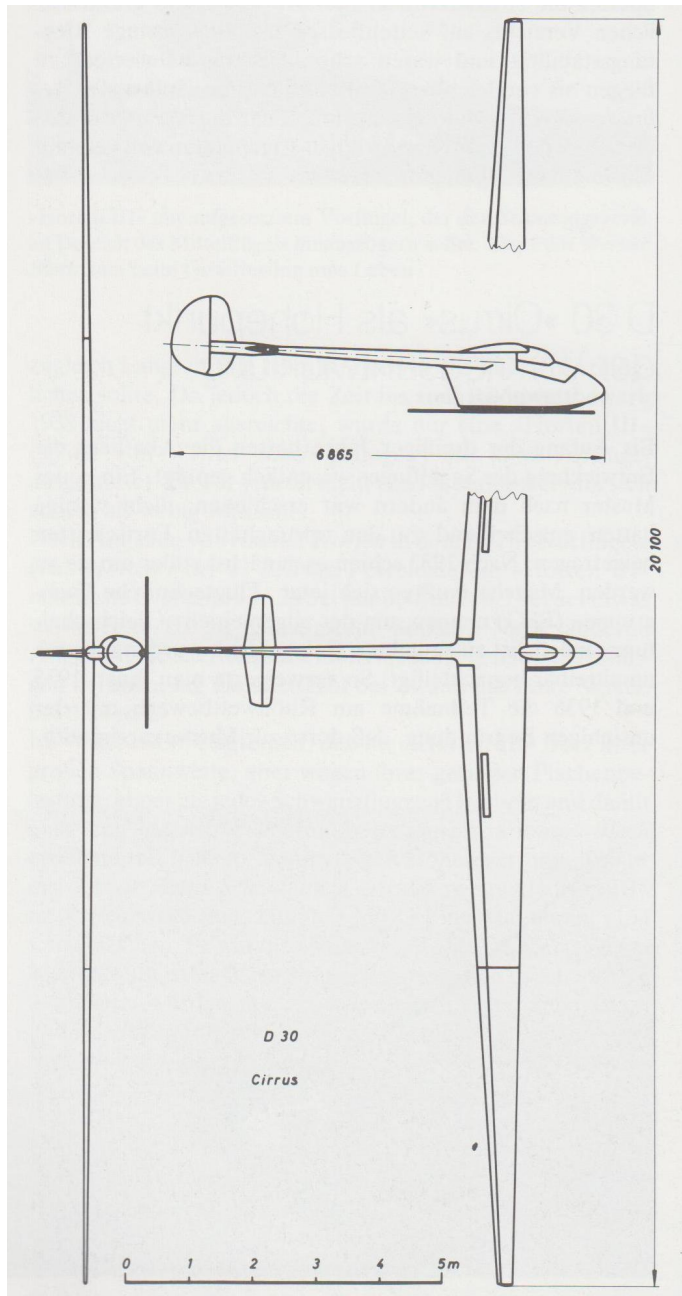

Fig. 5: Akaflieg Darmstadt D 30 "Cirrus", 1933.

remarkable cross-country flights, which confirmed the design principles.

One widely known member of the Akaflieg München is Egon Scheibe, who was one of the lead Akaflieg München students during the "Milan" and Mü 13 era. Subsequently, until the late 1980s, Scheibe designed and built his well-known "SF"-types in his company as follow-on designs of the "Münchener Schule".

The FVA 10 that was designed and built by the Akaflieg Aachen, was an aerodynamically well shaped project with "gull-wings". The canopy consisted of a complex framework of sev-

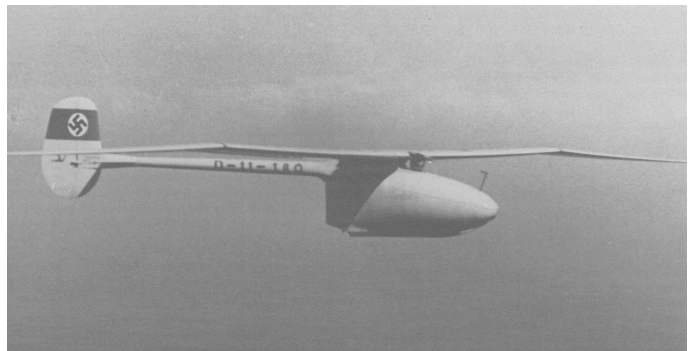

Fig. 6: D 30 test flight; note the negative dihedral of the outer wings.

eral plane Plexiglas panels and was contoured with the front cockpit, giving the fore part of the fuselage a more streamlined shape, Fig. 9.

The fs 18 of the Akaflieg Stuttgart flew first in 1938. It demonstrated the potential of reducing parasitic drag by minimizing the fuselage surface behind the cockpit and using a retractable landing gear. Handling was improved by installing the new DFS-airbrakes and efficient wing-flaps that consisted of three segments.

Examples of Idaflieg-group designs since 1951

After soaring was permitted again in Germany in 1951, the Akaflieg-groups were revived. Very soon, the first designs were started. Reduction of friction drag by improving natural laminar flow was an exciting challenge to the students. New high-performance sailplanes, built in the USA and other countries, had become the driving designs in soaring. These developments were based on new aerodynamic theories and knowledge, for example the investigations of boundary layers by Dr. August Raspert of the Mississippi State University in the USA.

Inspired by these works, Richard Eppler and Hermann Nägele from the Akaflieg Stuttgart developed the fs 24 "Phönix", Fig. 11, with a computer-calculated natural laminar flow profile for the wing. Laminar flow wings require very precise and impeccable surfaces with respect to shape accuracy as well as surface roughness, as Dr. Raspert had determined. Therefore, the fs 24 became the first glider with a fiberglass-balsa-



Fig. 7: Akaflieg München Mü 10 "Milan" from 1934.

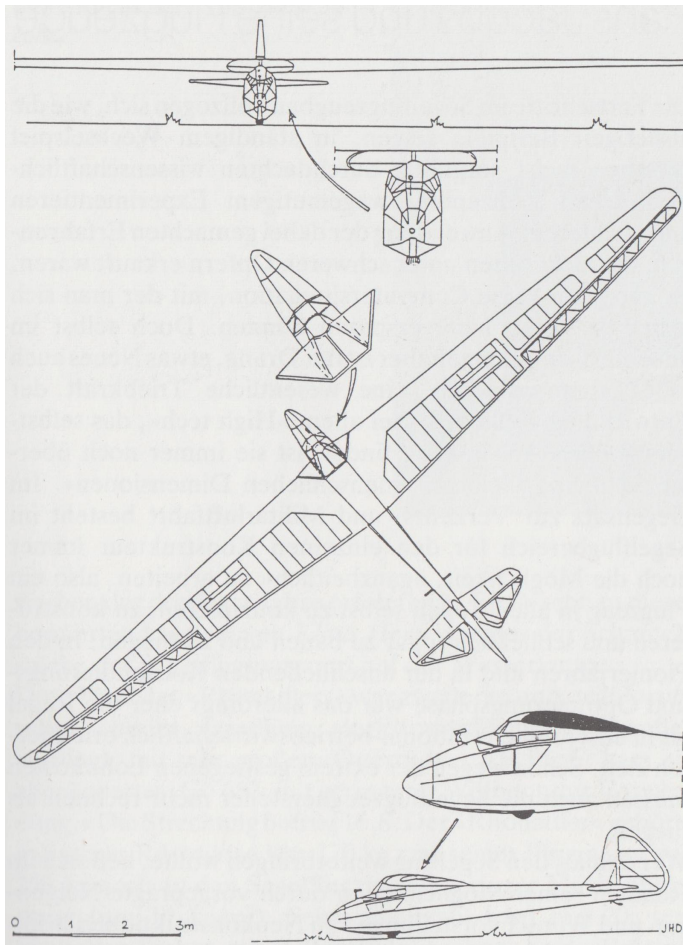

Fig. 8: Akaflieg München Mü 13 “Atalante” from 1935.

sandwich structure as technology enabler for laminar flow. It was built outside-in, using negative molds that were highly precise in shape for their time, Fig. 12. Both design features, extensive laminar flow and composite structures, made the fs 24 the “grandfather” of the next glider generations. The fs 24 pro-



Fig. 9: FVA 10a in flight, 1935.

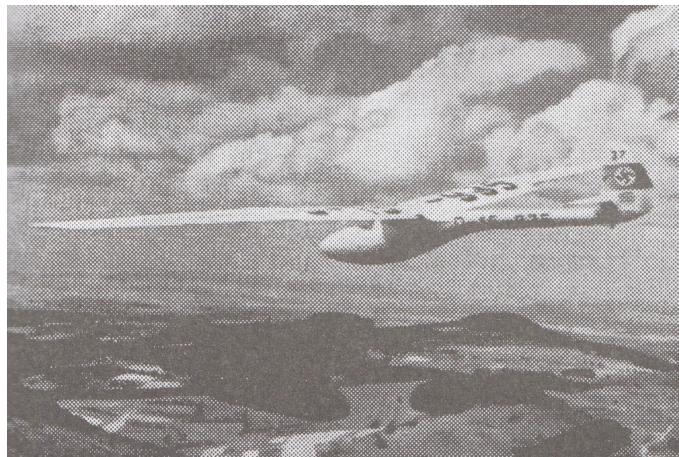

Fig. 10: fs 18 of Akaflieg Stuttgart flying over the Rhön area, 1938.

duction method remains in use in principle until today and without doubt the “Phönix” is a benchmark of glider design. The successful first flight of the prototype was on September 11th, 1957.

Within approximately one decade, the Akaflieg Braunschweig designed, built and operated a noteworthy series of new and successful prototype sailplanes that used composite structures (SB 6 (1961), SB 7 (1962), SB 8V1 (1967), SB 8V2 (1968), SB 9 (1969), SB 10 (1972), see Figs. 13 and 14) and had steadily increasing wingspans and masses, [1]. The SB 10, maiden flight that was in 1972, marked the limit of performance improvements, because larger dimensions and heavier weights were unfeasible for the typical Akaflieg. The innovative design was remarkable and became another milestone in sailplane and aviation development. As a novel feature the primary structure of its center wing section was made out of the relatively new material “carbon fiber reinforced plastic” CFRP. After 30 years of very



Fig. 11: fs 24 T, production version with T-tail, exhibited in the Segelflug Museum Wasserkuppe.

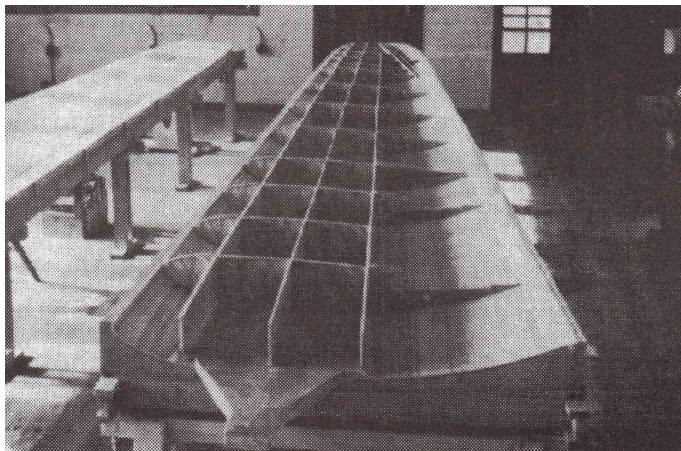

Fig. 12: Wing structure of the fs 24, built in molds.

successful flight operation, the SB 10 had reached the certification limit of flight-hours in 2002. Some elder, former members of Akaflieg Braunschweig made an extensive overhaul and since 2012 the SB 10 is flown again by the active group members.

The Akaflieg-prototypes mentioned are some examples of contributions to the design of sailplanes. Since 1951 until now the Idaflieg groups designed, built and flew in total more than fifty prototypes. Some have been in operation for more than sixty years after their first flight.

Variable wing geometry

In the 1970s and 1980s, some Idaflieg groups assessed, designed, built and flew prototypes that had wings with variable geometry. Variable geometry is an approach to improve cross-country performance. The basic idea of variable geometry is to have a glider that has optimized performance for climbing in an area of lift as well as for gliding to the next thermal. For a typical thermal with a maximum lift at its center, low flight speeds,



Fig. 13: SB 10 with 29m wingspan in flight.

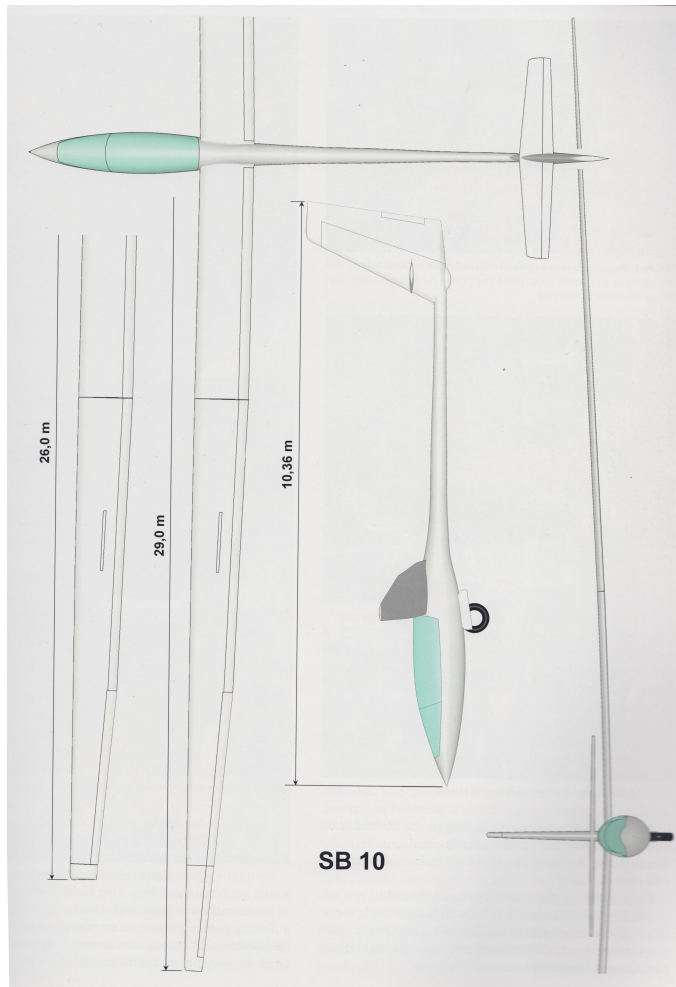

Fig. 14: SB 10 overview.

high lift coefficients, low wing loadings and a high aspect ratio are advantageous. In contrast to that, a high wing loading and small wing area are desirable for the interthermal glide, [2]. In Fig. 15, the principle effects of wing load and aspect ratio variation on an airspeed polar, which result from variable geometry, are illustrated.

Very different ideas and concepts of implementing such “two-point-designs” were discussed, investigated and realized throughout the soaring community. Examples, designed, built and flown in the 1960s are the Swiss Neukom AN 66C and the very challenging British project SIGMA. Either design had trailing-edge flaps similar to those of the AFH-4, Fig. 16, which had been designed by the Akaflieg Hanover already in 1938 and which could vary its wing area by about 13%.

The Suisse design AN 66 (Alfred Neukom) was constructed and built about 1966 to 1968, Fig. 17. The wing area could be varied with manually operated “wing-flaps”. The British project SIGMA, a complex metal-design, was started 1966, Fig. 18. After some problems during construction, first flight was on September 12th 1971 in Cranfield, UK. Hydraulically operated

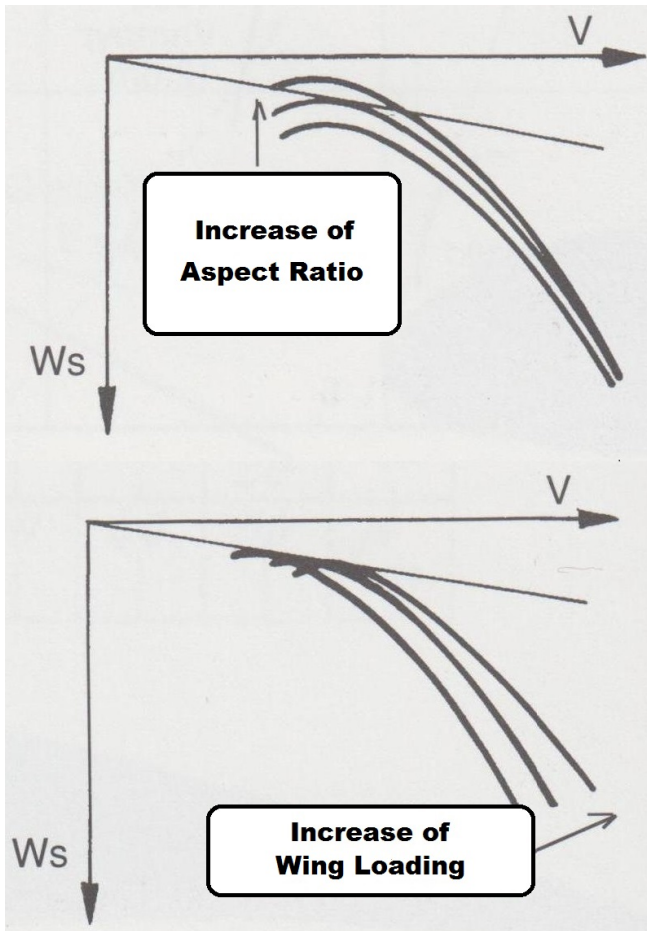
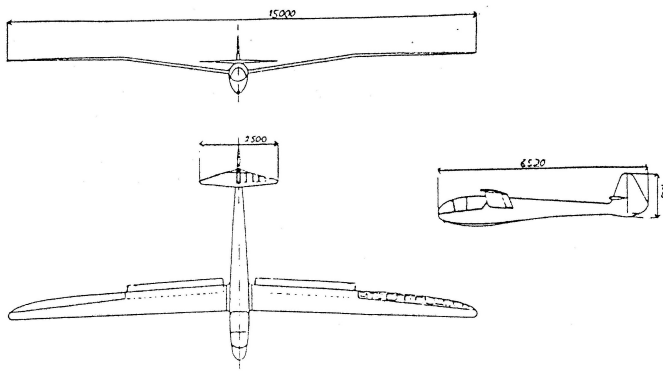

Fig. 15: Impact of changes in aspect ratio (top) and wing loading (bottom) on airspeed polar.



Typ	AFH 4	Baujahr	-1938
Konstruktion	Eppmann, Vollmer, Schwering		
Spannweite	15 m		
ger. Sinken	0,75 m/s		
Länge	6,5 m	Gleitzahl	27 bei 81 km/h
Flächeninhalt	10/11,3 m ²	Flügelprofil	NACA 23014/012
Rüstgewicht	170 kg		

Fig. 16: Akaflieg Hanover AFH 4 overview.

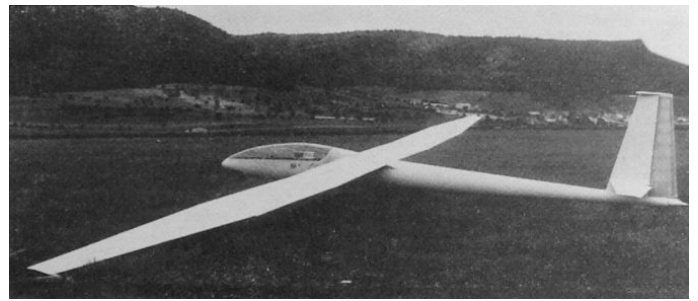

Fig. 17: Swiss made AN 66.

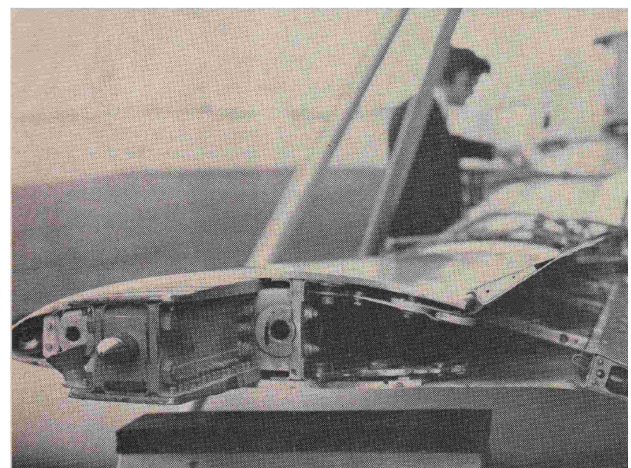
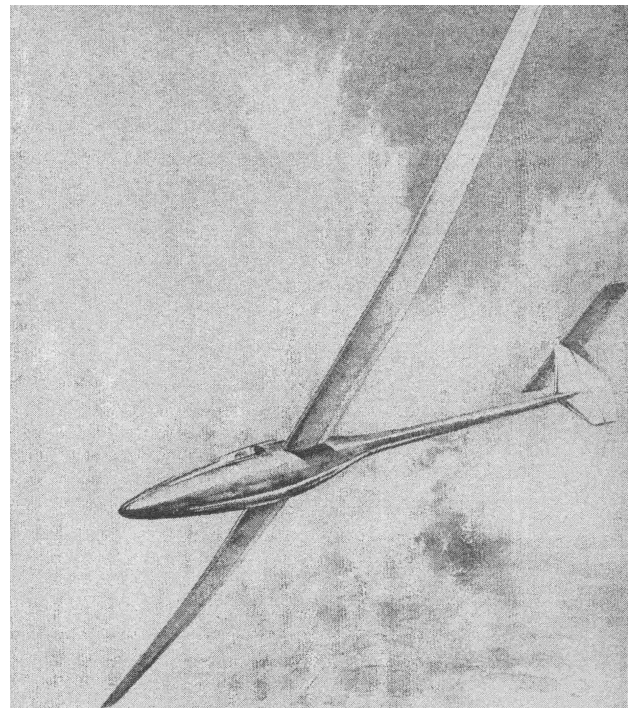

Fig. 18: SIGMA (top) and SIGMA wing section (bottom).

wing flaps changed the wing area by about 35%. Hydraulic flow and pressure for the flap actuator operation were generated by pumping hydraulic fluid with the rudder pedals. After several major modifications, SIGMA's performance was estimated at a maximum glide ratio of about 47. Handling qualities were reported to be acceptable. Nowadays, SIGMA is operated by David Marsden of the University of Alberta, Canada.

The following examples show some "two-point-design" projects that were realized in Idaflieg-groups with very different approaches to "variable geometry".

Akaflieg München - Mü 27 - "wing flaps"

The students in Bavaria were busy for a long time with the design of a two-seater with a complex wing flap system that is actuated using electrically driven jack-screws. Early concept studies and design work started in 1970. The wing airfoil of the 22m wing was the same Wortmann profile as used in the SIGMA-project. First flight with the very heavy Mü 27 (empty mass about 720 kg) was in 1979, Figs. 19, 20 and 21. The flap mechanism was very complicated and sensitive, and it took about 10 seconds to change the wing configuration. Performance was satisfactory but the Mü 27 was not convenient for a normal flight operation – it simply was too heavy and required too much maintenance. The last flight was in October 2009 to the Deutsches Museum at Munich, 22, as a permanent exhibit.

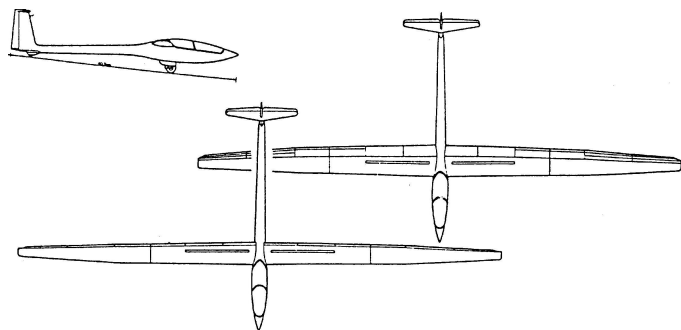

Fig. 19: Mü 27 overview.

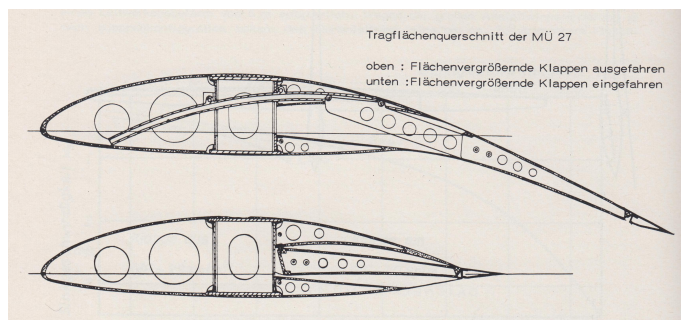

Fig. 20: Mü 27 wing flap schematic.

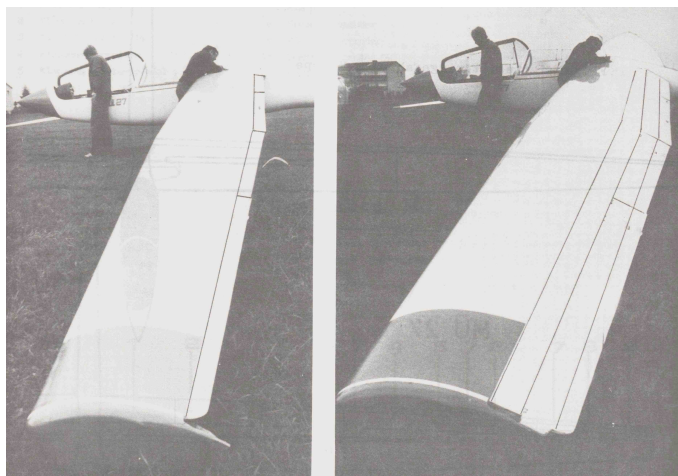

Fig. 21: Mü 27 wing flaps retracted (left) and deployed (right).



Fig. 22: Mü 27 in flight.

Akaflieg Stuttgart - fs 29 - "telescopic wing"

About 30 student-members participated in the design and construction of this highly complex project that lasted from 1972 to 1975 – the fs 29 with the so called "telescopic wing", Figs. 23, 24 and 25. With this concept the outer wings slide over the inner wings to increase or reduce wing span, which can be selected between 19m and 13.3m. Actuation is manually by using a "ratchet-like" lever. But the complicated and touchy mechanism made it difficult and impracticable for normal flight operation. The configuration changes from low aspect ratio – outer wings "in" for interthermal glide – to high aspect ratio - outer wings "extended" for circling in thermals - were challenging. The outer wings were moved by a cockpit-handle, with a maximal travel of about 0.5m per stroke. The forces required to slide the outer wings were high and it needed about six to seven strokes with the handle to change the configuration. Therefore,

in 2000 the group decided to ground the fs 29. Currently it is exhibited in the “Deutsches Museum”.

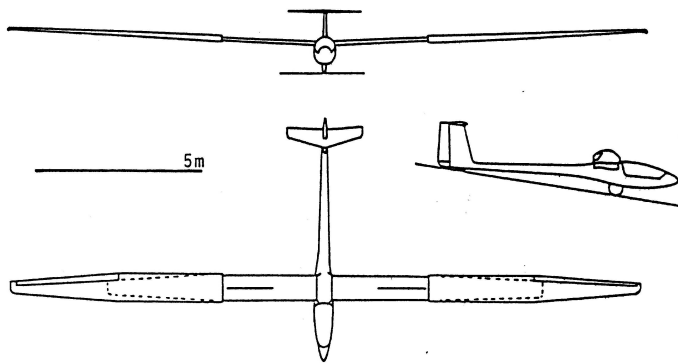

Fig. 23: fs 29 overview.

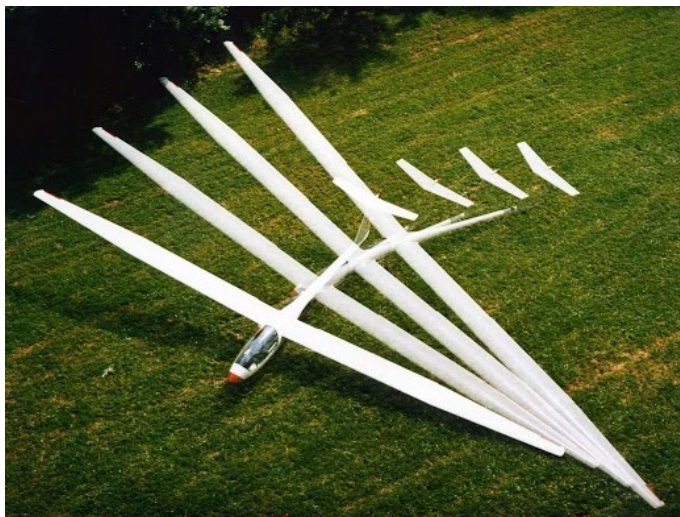

Fig. 24: fs 29 variable wing span.

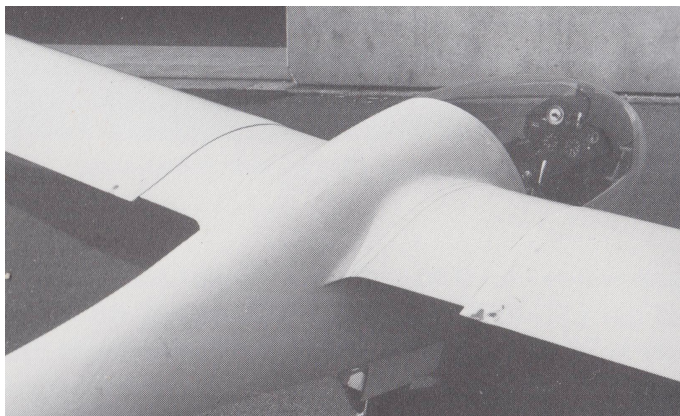

Fig. 25: fs 29 outer wing partly extended.

Akaflieg Braunschweig - SB 11 - “wing flaps”

The students of the Akaflieg Braunschweig decided to develop their “dual-point-design” project SB 11 with “wing flaps”, Fig. 26, that allow for a variable wing area. Preliminary studies were performed in 1974. The students built several test rigs in order to check the complicated flap-mechanism. In a series of free flight measurements, the theoretical aerodynamic characteristics of the designed airfoil section (essentially a Wortmann profile, modified by the group members Horstmann and Quast, later famous for their HQ series glider-profiles) were confirmed for different “wing flap” settings. For these measurements, a sensor-equipped wing model was mounted between large endplates on top of a Kranich III in front of the pilots, see Fig. 27.

The wings had to be very stiff for an easy and jam-free flap operation under aerodynamic load, but bending and torsion could only be carried by the spar and the wing leading edge D-tube. Therefore, a structure made entirely out of carbon-fiber reinforced composites was realized. The SB 11 was designed in accordance with the then new FAI-class rules that have as the only limiting parameter a 15-meter wing span. The wing-flaps allowed to vary the wing area between 10.56m² and 13.20m², Fig. 28.

The first flights on May 14th 1978 and a short qualitative flight testing of the SB 11 showed good handling characteristics and no other critical items. Only two month after the maiden flight, Helmut Reichmann won the world championship 1978 with the SB 11. Due to its good flight performance and comfortable handling characteristics, the prototype SB 11 is part of the group fleet until today, Fig. 29.

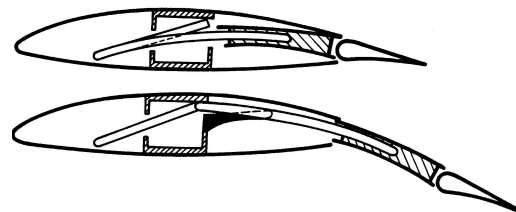

Fig. 26: SB 11 principle of wing flaps.



Fig. 27: Free-flight airfoil testing.

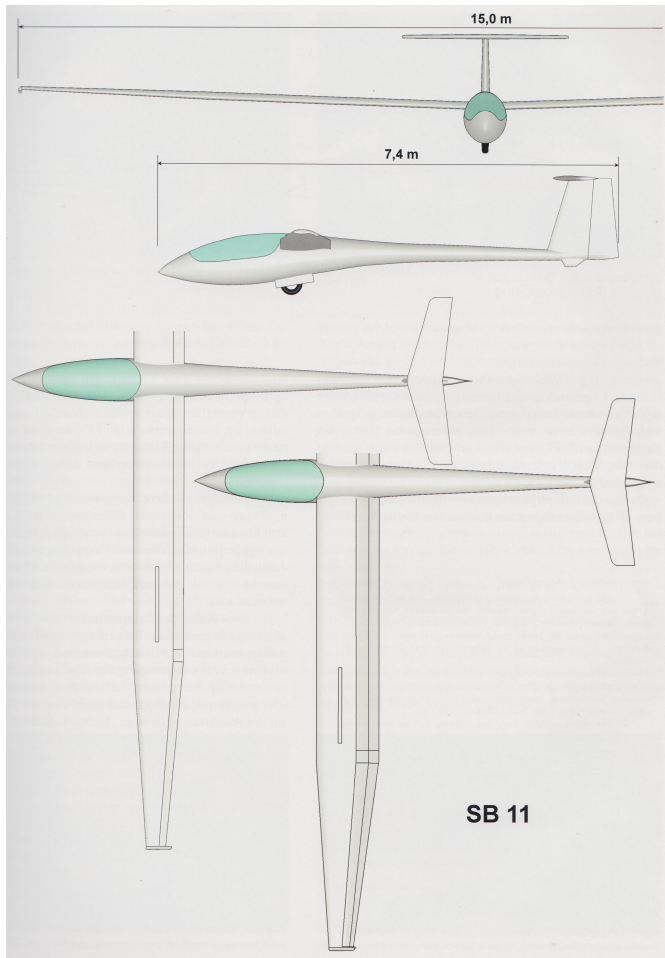

Fig. 28: SB 11 overview.

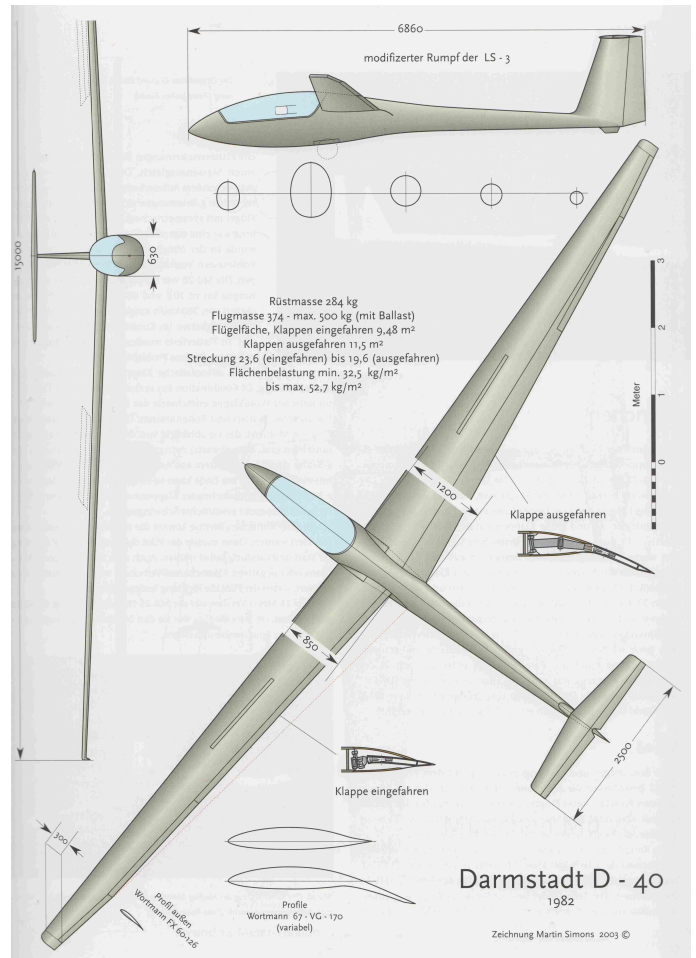

Fig. 30: D 40 overview, [3].



Fig. 29: SB 11, the first glider with an all carbon-fibre structure, in flight.

Akaflieg Darmstadt- D 40 - "Pocket-Knife-Wing"

The Akaflieg Darmstadt designed a wing with variable wing area by deflecting a flap around a bearing at the inboard end of the aileron, Fig. 30 and Fig. 31. When deploying the flap,

it looks like swinging open a pocket-knife. Chord at the wing root varies between 0.85m and 1.20m. Flight testing started in 1986 after six years of development, construction and building. Presently, the D 40 is operated by a former member of Akaflieg Darmstadt.



Fig. 31: D 40 "pocket-knife-wing-flaps" retracted.

Table 1: Some characteristic data of Akaflieg prototypes with variable geometry.

Type	Concept	wing area (m ²)	area mod.	area load (kg/m ²)
Mü 27	“wing flaps”	23.9-17.6	+38%	43.5-51.1
fs 29	“telescopic wing”	12.65-8.56	+48%	36.5-52.6
SB 11	“wing flaps”	13.2-10.56	+25%	35.6-44.5
D 40	“pocket-knife-wing”	11.5-9.5	+21%	32.0-51.5
fs 32	“gap-fowler-wing”		minor	

Akaflieg Stuttgart - fs 32 - “Gap-Fowler-Flap”

Based on the experience with the “telescope-wing” design of the fs 29, a next generation of Akaflieg Stuttgart students tried another approach. They decided to develop a wing with a retractable slotted wing flap similar to a Fowler-flap, Figs. 32, 33 and 34. After about ten years of development and construction the successful maiden flight was performed in 1992. However, it should be noted that the very complex flap-mechanism required about 1,500 parts for each wing half. Presently the prototype fs 32 is operated by a former group member.

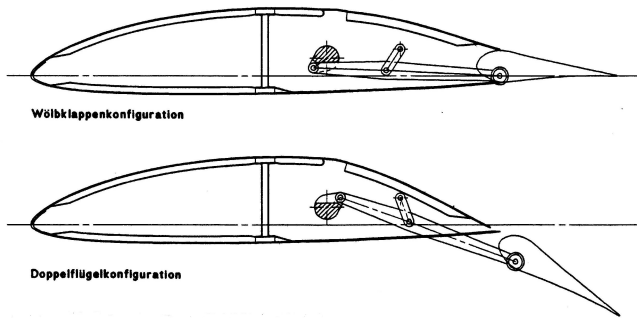

Fig. 32: fs 32 “Fowler-flap” arrangement.



Fig. 33: fs 32, flaps extended.

It should be noted that, until now, none of the mentioned principles of variable geometry wings for performance gliders



Fig. 34: fs 32 in flight.

found its way into a production version, obviously the advantages are not great enough to accept the complexity, cost or poor handleability of the Akaflieg-versions of “two-point-designs”. Table 1 gives an overview on the variation of wing area and wing loading attainable with the different variable geometry concepts.

Examples of unconventional Akaflieg-projects

Commercial success is not a driving factor for the Akaflieds. Therefore, over the history of the Idflieg-groups, the students of all generations have had the freedom to experiment with new ideas within the limits of budgets and manpower. They have been able to initiate risky and unconventional projects. Several very special and exotic designs have been developed that are subsequently presented.

In 1955/56, students of the University of Aachen adapted an idea that was originally developed by NACA in the 1930s - they designed a glider with a ring-shaped wing, the FVA 14, Fig. 35. When testing a wind tunnel model, they determined that the glider would be uncontrollable at certain angles of attack and the project was ultimately cancelled.

The Akaflieg Berlin participated with its first design, the tail-less glider B 1 “Charlotte”, Fig. 36 at the Rhön-meeting in 1923. After a crash, it was redesigned and became the B 3.

Near the end of WW II, the Akaflieg groups Darmstadt (D) and Munich (M) built the delta-wing design DM 1, Fig. 37, of Alexander Lippisch as an experimental glider. Directly after the war, the DM 1 was finished by students in the workshops of Akaflieg München on initiative of US Army Air Force experts.

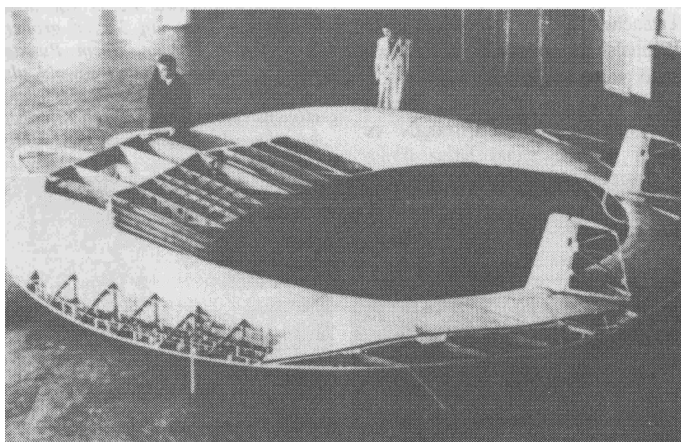

Fig. 35: FVA 14, a unique glider concept.

Thereafter it was transported to the US for wind-tunnel testing. Today, the DM 1 has been restored for exhibition in the National Air and Space Museum, Washington, DC.

Before soaring was allowed again after WW II, former members of Akaflieg München and “soaring-minded” students created a working group called “Strömungsmechanik” (Fluid Dynamics). They designed and built a rigid sail, similar to a vertical glider wing, with a symmetric NACA 0012 profile. The rigid sail was tested utilizing their sailing boat, Fig. 38, on lake Chiemsee, adjacent to their old hangar at Prien. However, the Akaflieg München rigid sail was destroyed during very windy and turbulent weather conditions.

In the early sixties, Akaflieg Esslingen designed a glider with a very short fuselage and forward swept wing, the E 11, Fig. 39. The empty weight became very high and, although planned as a two-seater, only one light pilot could fly it. The handling qualities were poor and after only a few flights the students destroyed their prototype.

Another example of a tailless glider is the Akaflieg Braunschweig SB 13, Fig. 40. After six years of intensive concept



Fig. 36: B 1, one of the early tailless glider designs.

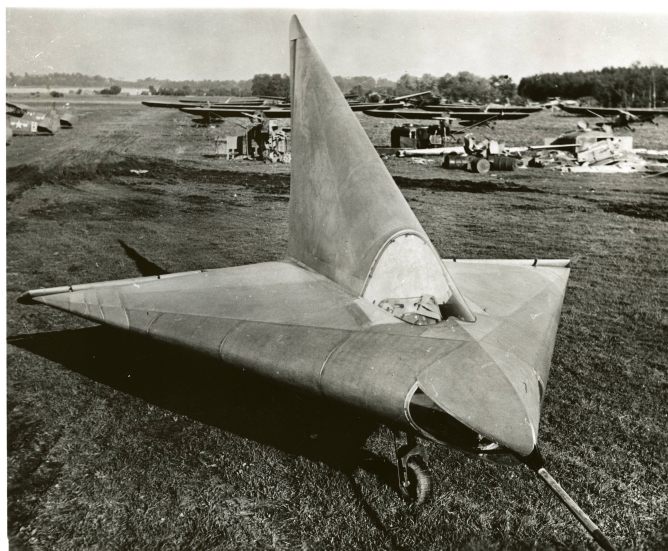

Fig. 37: The DM 1 Prototype at Prien airfield near Lake Chiemsee.

studies, model testing, construction and building, the prototype started for the maiden flight on March 18th 1988. During flight test many modifications were evaluated to improve handling qualities and airplane behavior. Especially stalling characteristics turned out to be dangerous and it was necessary to introduce boundary layer fences on the 15° aft-swept wings. Nevertheless, the SB 13 exhibited good flight performance but its demand on high piloting skills caused the group to terminate flying the SB 13. Many interesting results from testing campaigns were documented. In 2006 it was brought to the Deutsches Museum

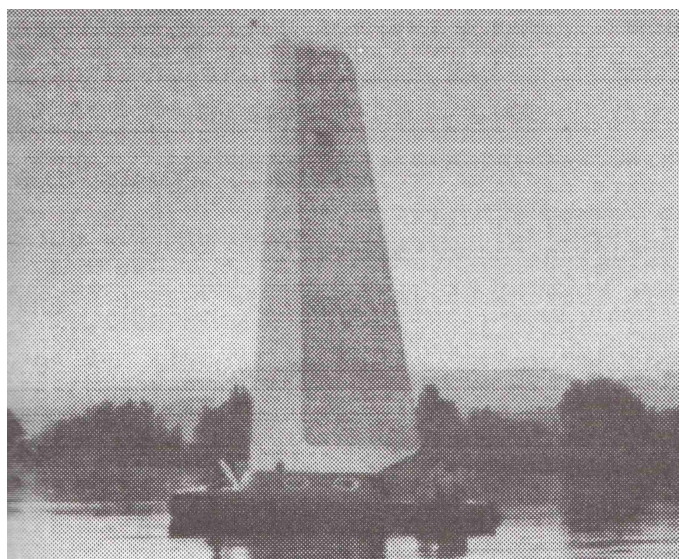

Fig. 38: When aeronautical activities were not allowed in Germany, the Bavarian students designed, built and, obviously, tested a rigid sail.



Fig. 39: E 11 - after only a few flights, the students destroyed their prototype.



Fig. 40: SB 13 during flight test.

in Schleissheim near Munich on loan.

Several powered airplanes also were designed by various Akaflieg groups. As an example, the fs 26 of Akaflieg Stuttgart is shown in Fig. 41, which first flew in 1969.

Idaflieg activities

From the very beginning of Akaflieg groups, students have met for the so called “Vergleichsfliegen” at the Idaflieg summer meeting held every year in August for 3 to 4 weeks, [4]. During the meeting, sailplanes are systematically evaluated and tested. Initially these testing activities were constraint to the designs of the different student groups, but today also commercial sailplane manufacturers often make available their latest prototypes. In order to get comparable results, it was soon realized that standardized and well defined testing methods and criteria are necessary. The first meeting with technical flights according to a specified program with documented pilot comments and

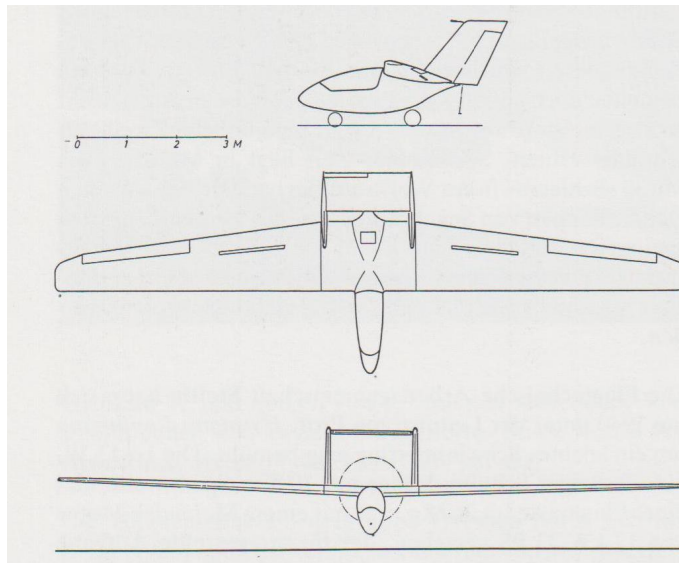

Fig. 41: fs 26 overview.

reports took place in Aachen in 1937.

As in the early days of these meetings, young Akaflieg-pilots participating for the first time are introduced to the testing and evaluation methods by more experienced members, who are assisted by one or two professionals from universities or other research institutions. This “Zachern”, as the systematic in-flight glider evaluation is now called in memory of Hans Zacher, is taught in theory and practice. Pilots learn to use simple equip-



Fig. 42: Cockpit with very simple test tools used for “Zachern”.

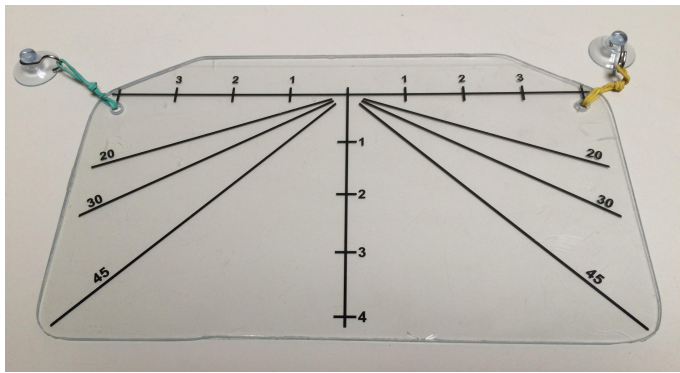

Fig. 43: The “phi-psi-theta”.

ment, Fig. 42, the standard control techniques and inputs, and how to present and document data and observations. The outcomes are reported and discussed in teams at the meetings.

For non-standard applications, the groups design and build special sensors, data handling, registration and presentation equipment. Because of limited financial resources, the equipment often is simple but effective: Aircraft attitude changes due to control inputs or in turbulent air are estimated by observing the so called “phi-psi-theta”, fixed in the pilots field of view - “phi” for angle of bank, “psi” for angle of yaw and “theta” for pitch angle, Fig. 43. Stick position and control surface deflections, mainly for the elevator, are measured using a tape measure that is fixed to the control column and instrument panel, Fig. 44. Hand forces for pitch and roll control are measured using spring scales, Fig. 45. With these methods and tools, many different aircraft, especially Akaflieg prototypes but also industrial gliders, are tested. Measurement results and observations are documented on a standardized test sheet, the “Zacher-Protokoll”, Fig. 46 and discussed subsequently among the young pilots.

The results of, for example, cockpit evaluations have found their way into certification regulations and recommendations for



Fig. 44: Tape roll for attachment at the control-stick.



Fig. 45: Hand forces for pitch and roll control are measured using spring scales.

the layout and arrangement of control and operating devices that enable an intuitive actuation. Handling safety is supported by shape and color of control handles, checked and judged during Idaflieg-summer meetings. This is an example of how to improve passive flight safety.

Another example for testing procedures at the summer-meeting are special exercises that improve the students understanding of flying at high angles of attack and how to react correctly in such flight conditions. Experiencing spinning, the warnings of airflow separation, the gliders behavior beyond maximal AoA (angle of attack) and control inputs that are required for recovery are part of the program to prepare a “fresh” pilot, who, at some point, has to test a prototype with unknown characteristics.

Measuring the speed polar

During the annual summer-meeting, the sailplane-performance measurements are an important element. Everything must be ready and prepared for an early take-off at sunrise to measure in calm, undisturbed air. Usually, one or two

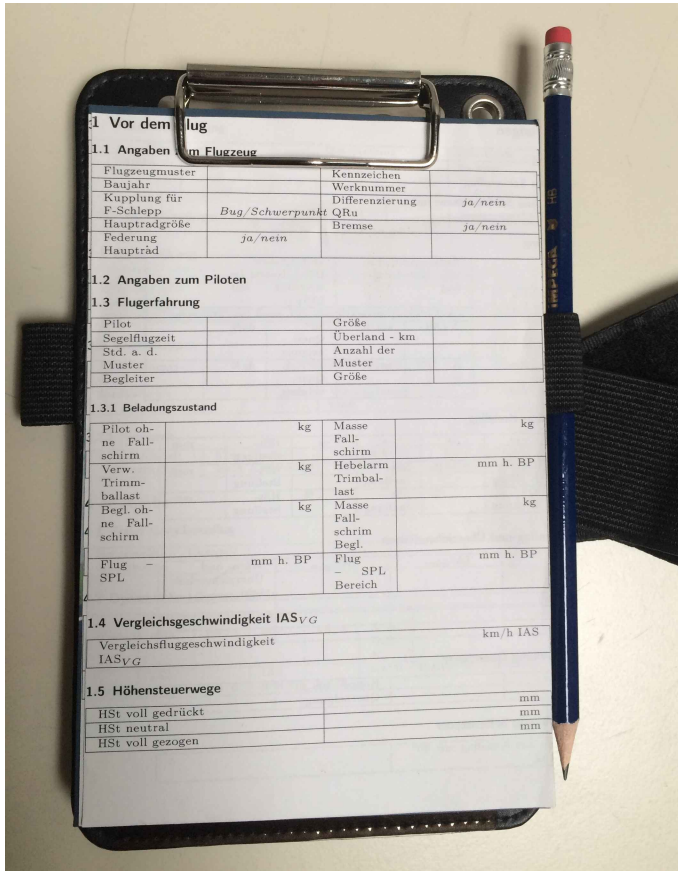

Fig. 46: A typical Flight Test Card (“Zacher-Protokoll”) to document observations and measurement results.

missions are performed before atmospheric turbulence begins. The pilots are specially trained for stable formation flying.

Over the course of 65 summer meetings during the nearly centennial history of Idaflieg, the procedures and techniques have continuously been assessed and improved. Several different methods of performance-flight measurement have been investigated and explored, such as solo altitude steps or approaches considering energy analysis while decelerating.

But to date, the most accepted and best established procedure for measuring the flight performance of sailplanes, expressed by the airspeed polar, is formation flying with a reference glider. The Flight Research Department of the German Aerospace Center DLR operates one for this purpose. Currently, an especially modified Discus 2c is used, which can be seen in formation flight in Fig. 47 together with its predecessor DG 300/17. The reference glider is equipped with extensive instrumentation. Its performance is well known from frequent calibration flights. The performance of the glider that is being evaluated is determined by comparing the differences in changes of altitude over a time interval, while both gliders fly through the same air mass at exactly the same airspeed. The experimental determination of the speed polar is a great validation of the prediction and estimation



Fig. 47: The “holy” reference glider Discus 2c-DLR in formation with its predecessor, the DG 300/17, during a test run.

methods that were used during the design phase.

The accuracy of measuring the flight-performance data has been steadily improved and is widely accepted, even if the performance of the “candidate” is below the expectations of those of the “parents”.

Idaflieg winter-meeting

During winter time, the students meet for several days in order to present and discuss the status of their projects, special investigations and internal organizational items. This annual “assembly” is an important aspect of the internal “functioning” of the Idaflieg.

Seminars and short-courses

Beyond the regular meetings during summer and winter, Idaflieg organizes additional courses and events. For example, the design seminar, organized by Akaflieg Stuttgart, was originally established when new materials and manufacturing technologies replaced wood and fabric. The application of innovative design and construction software that are utilized for Akaflieg projects has always been part of the annual design seminar. Another example for Idaflieg courses is the aerobatics training camp that the Idaflieg offers its members in order to improve and expand the piloting skills. During this camp, students learn to react proficiently in unusual attitudes, subsequent recovery techniques and precise flying in all flight phases. Besides these courses that are organized by Idaflieg, several other courses are offered every other year or on demand, for example a soaring contest for Akaflieg prototype designs or an introductory course to project management.

Summary

Founded by aviation enthusiastic students about hundred years ago, German Akaflieds designed, constructed and flight tested a large number of prototypes (more than 150!) that strongly influenced the evolution of gliders and sailplanes. Some of the designs became important milestones, such as the fs 24

“Phönix”, grandfather of all modern sailplanes made from composite material and utilizing extensive laminar flow. With other Akaflieg projects, misleading concepts could clearly be identified and sorted out. Today, the Akaflieds are still very active. Information about their current projects can be found on the homepages of individual groups. The same applies for the Idaflieg (Internet addresses are given below in section “References”).

Finally it should be noted that German sailplane industry profited and still profits from Akaflieg and Idaflieg activities not only through technical achievements but also from the numerous designers who often started their engineering career as a member of one of the Akaflieds.

References

- [1] Akademische Fliegergruppe Braunschweig, editors, *SB 5 – SB 15, Segelflugzeug Braunschweig*, Appelhans-Verlag, Braunschweig, 2012, ISBN 978-3-941737-73-0.
- [2] Thomas, F., *Fundamentals of Sailplane Design*, College Park Press, 1991, ISBN 0-9669553-0-7.
- [3] Simons, M., *Segelflugzeuge 1965 – 2000*, EQIP Verlag GmbH, Bonn, 2nd ed., 2017, ISBN 978-3980883801.
- [4] Idaflieg, “50 Jahre Vergleichsfliegen, 1937 – 1987.” Tech. rep., Idaflieg, Aachen, 1987.

Appendix

The article gives an overview on the Akaflieds and their umbrella organisation Idaflieg. The material presented is partly based on own experience of the author (who was an active member of Akaflieg Braunschweig), but mainly on the archives of the student groups. Therefore, additional to the references above, internet addresses of Idaflieg and her member groups are given. The reader is encouraged to visit the homepages where further information as well as contact addresses can be found.

- Idaflieg
<http://idaflieg.info> (in German and English)
- Flugwissenschaftliche Vereinigung Aachen (FVA)
<http://www.fva.rwth-aachen.de> (in German and English)
- Akaflieg Berlin
<https://akaflieg-berlin.de> (in German)
- Akaflieg Braunschweig
<http://www.akaflieg-braunschweig.de> (in German)
- Akaflieg Darmstadt
<http://www.akaflieg.tu-darmstadt.de> (in German)
- Akaflieg Dresden
<https://www.akaflieg-dresden.de> (in German)
- Flugtechnische Arbeitsgemeinschaft Esslingen
<http://ftag.alfahosting.org> (in German)
- Akaflieg Hannover
<https://www.akaflieg-hannover.de> (in German)
- Akaflieg Karlsruhe
<https://akaflieg-karlsruhe.de> (in German)
- Akaflieg München
<http://www.akaflieg.vo.tum.de> (in German)
- Akaflieg Stuttgart
<https://akaflieg.hg.stuvus.uni-stuttgart.de> (in German)

For some of the content shown in Fig. 1 to Fig. 47 the copyright is unknown. In these cases the material is reproduced according to section 107 of the US Copyright Act, which defines “Fair Use” as follows: The fair use of a copyrighted work, including such use by reproduction in copies or phonorecords or by any other means specified by that section, for purposes such as criticism, comment, news reporting, teaching, scholarship, or research, is not an infringement of copyright.